

Service Manual

COMPACT
disc
DIGITAL AUDIO

*
DOLBY B NR

CD Stereo System
SA-CH11

Colour

(K) ... Black Type



SB-CH11

SA-CH11

SB-CH11

Area

Suffix for Model No.	Area	Colour
(E)	Continental Europe	(K)
(EB)	Great Britain	
(EG)	F.R. Germany/Italy	
(GN)	Oceania	

System Name	Unit	
SC-CH11(GN)	SA-CH11(GN) SB-CH11(G)	Music center Speaker
SC-CH11(E/EB/EG)	SA-CH11(E/EB/EG) SB-CH11(E)	Music center Speaker (PAES)

* Dolby noise reduction manufactured under license from Dolby Laboratories Licensing Corporation.
"Dolby" and the double-D symbol are trade marks of Dolby Laboratories Licensing Corporation.

TAPE DECK : MECHANISM SERIES (AR300)

TRAVERSE DECK : MECHANISM SERIES (SODD110Z)

■ SPECIFICATIONS

■ AMPLIFIER SECTION

1 kHz continuous power output both channels driven	2 x 20 W (THD 1%, 6 Ω)
Total harmonic distortion half power at 1 kHz	0.07% (6Ω)
Frequency response	
AUX	30 Hz — 30 kHz (-3 dB)
Input sensitivity	
AUX	250 mV
Input impedance	
AUX	24 kΩ
Graphic equalizer	± 10 dB (100 Hz, 330 Hz, 1 kHz, 3.3 kHz, 10 kHz)

■ FM TUNER SECTION

Frequency range	87.50 — 108.00 MHz
Sensitivity	23.3 dBf (4.0 μV, IHF '58)
Total harmonic distortion	
MONO	0.3%
STEREO	0.5%
S/N Ratio	
MONO	70 dB
Frequency response	30 Hz ~ 15 kHz (+0.5 dB, -2 dB)
Image rejection at 98 MHz	40 dB
Stereo separation	
1 kHz	35 dB
Antenna terminal(s)	75 Ω (unbalanced)

■ LW/MW TUNER SECTION

Frequency range	
MW	522 — 1611 kHz
LW	144 — 288 kHz
Sensitivity (for 500 mW)	
MW (at 999 kHz)	250 μV/m
LW (at 252 kHz)	350 μV/m

■ CASSETTE DECK SECTION

Track system	4 - track, 2 - channel
Heads	
Playback	Solid Permalloy
Record/Playback	Solid Permalloy
Erasure	Double gap ferrite head
Motor	DC servo motor
Recording system	AC bias, 100 kHz
Erase system	AC erase, 100 kHz
Tape speed	4.8 cm/sec
Frequency response	
NORMAL	40 Hz—14 kHz (+3, -6 dB)
CrO ₂	40 Hz—14 kHz (+3, -6 dB)
S/N (CrO ₂ type tape)	
Dolby NR off	52 dB (A-WTD)
Dolby NR on	61 dB (CCIR)
Wow and Flutter	0.1% (WRMS)
Fast forward and rewind time	

Approx. 110 seconds with C-60 cassette tape

Panasonic

CD PLAYER

Sampling frequency	44.1 kHz
Decoding	16-bit linear
Beam Source/wave length	Semiconductor laser/780nm
Number of channels	2 - channel, Stereo
Frequency response	20 Hz-20 kHz (+1, -2 dB)
S/N Ratio	90 dB filter (JIS. A)
Wow and Flutter	Below measurable limit
Digital filter	4 times over sampling
D/A converter	Multi stage noise shaping

GENERAL

Power consumption	95 W
Power supply	AC 50 Hz, 230 — 240 V
Dimension (W x H x D)	215 x 319 x 338 mm
Weight	6.9 kg





Notes :

- Specifications are subject to change without notice.
Weight and dimensions shown are approximate.
- Total harmonic distortion is measured by the digital spectrum analyzer.

CONTENTS

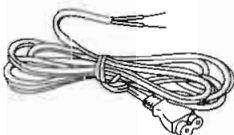
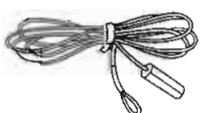
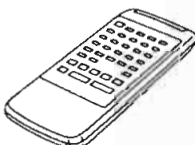
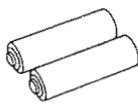
	Page		Page
ACCESSORIES.....	2	SCHEMATIC DIAGRAM.....	40 ~ 56
PRECAUTION OF LASER DIODE.....	3	PRINTED CIRCUIT BOARD.....	57 ~ 62
HANDLE PRECAUTIONS FOR TRAVERSE DECK.....	4	WIRING CONNECTION DIAGRAM.....	63 ~ 64
PROTECTION CIRCUITRY.....	4	DIGITAL SERVO SYSTEM.....	65 ~ 66
BEFORE REPAIR AND ADJUSTMENT.....	4	TROUBLESHOOTING GUIDE.....	67 ~ 68
FRONT PANEL CONTROLS AND FUNCTIONS.....	5 ~ 9	CABINET PARTS LOCATION.....	69 ~ 70
DISASSEMBLY INSTRUCTIONS.....	10 ~ 20	REPLACEMENT PARTS LIST.....	71 ~ 76
MEASUREMENTS AND ADJUSTMENTS.....	21 ~ 25	RESISTORS & CAPACITORS.....	77 ~ 83
TERMINAL FUNCTION OF IC'S.....	26 ~ 31	MECHANISM PARTS LOCATION (DECK 1).....	84 ~ 86
INTERNAL CONNECTION OF FL.....	31	(DECK 2).....	87 ~ 89
BLOCK DIAGRAM.....	32 ~ 38	TRAVERSE DECK PART.....	90 ~ 91
TERMINAL GUIDE OF IC's TRANSISTORS AND DIODES.....	39	PACKING.....	92 ~ 93

ACCESSORIES

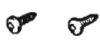
<p>AC power supply cord.....1 pc.</p> 	<p>FM indoor antenna1 pc.</p> 
<p>Remote control transmitter RAK-SC307WM.....1 pc.</p> 	<p>Remote control batteries UM-4, AAA, R03.....2 pcs.</p> 
<p>LW/MW loop antenna SLA9Z5T.....1 pc.</p> 	<p>Antenna holder.....1 pc.</p> 
<p>Attaching plug1 pc. (For United Kingdom only)</p> 	<p>Mounting screws.....2 pcs.</p> 

PRECAUTION OF LASER DIODE

CAUTION : This product utilizes a laser diode with the unit turned "on", invisible laser radiation is emitted from the pick up lens.

Wave length : 780 nm

Maximum output radiation power from pick up : 100 mW/VDE

Laser radiation from the pick up lens is safety level, but be sure the followings:

1. Do not disassemble the optical pick up unit, since radiation from exposed laser diode is dangerous.
2. Do not adjust the variable resistor on the pickup unit. It was already adjusted.
3. Do not look at the focus lens using optical instruments.
4. Recommend not to look at pick up lens for a long time.

ACHTUNG: Dieses produkt enthält eine laserdioden. Im eingeschalteten zustand wird unsichtbare laserstrahlung von der lasereinheit abgestrahlt.

Wellenlänge : 780nm

Maximale strahlungsleistung der lasereinheit : 100µW/VDE

Die strahlung an der lasereinheit ist ungefährlich, wenn folgende punkte beachtet werden:

1. Die lasereinheit nicht zerlegen, da die strahlung an der freigelegten laserdioden gefährlich ist.
2. Den werksseitig justierten einstellregler der lasereinheit nicht verstellen.
3. Nicht mit optischen instrumenten in die fokussierlinse blicken.
4. Nicht über längere zeit in die fokussierlinse blicken.

ADVARESEL: I dette a apparat anvendes laser.

RQLS0021



RQLS0051



SQWD7



Obs:
Apparaten innehåller laser Komponent av höger laserklass än klass 1.

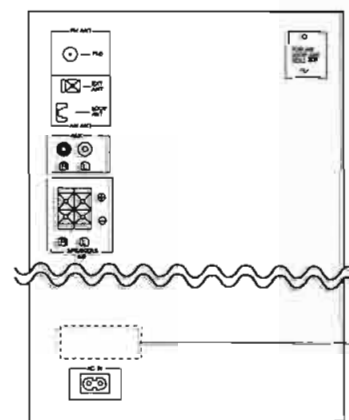
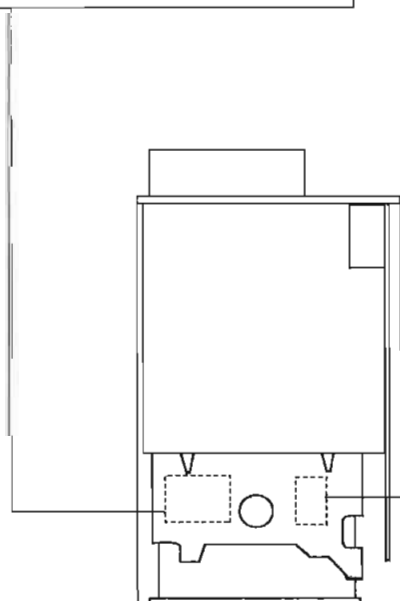

■ HANDLE PRECAUTIONS FOR TRAVERSE DECK

The laser diode in the traverse deck (optical pickup) may break down due to potential difference caused by static electricity of clothes or human body.

So, be careful of electrostatic breakdown during repair of the traverse deck (optical pickup).

• Handling of traverse deck (optical pickup)

1. Do not subject the traverse deck (optical pickup) to static electricity as it is extremely sensitive to electrical shock.

2. To prevent the breakdown of the laser diode, an anti-static shorting pin is inserted into the flexible board (FPC board).

When removing or connecting the short pin, finish the job in as short time as possible.

3. Take care not to apply excessive stress to the flexible board (FPC board).

4. Do not turn the variable resistor (laser power adjustment). It has already been adjusted.

• Grounding for electrostatic breakdown prevention

1. Human body grounding

Use the anti-static wrist strap to discharge the static electricity from your body.

2. Work table grounding.

Put a conductive material (sheet) or steel sheet on the area where the traverse deck (optical pickup) is placed, and ground the sheet.

Caution :

The static electricity of your clothes will not be grounded through the wrist strap. So, take care not to let your clothes touch the traverse deck (optical pickup).

■ PROTECTION CIRCUITRY

The protection circuitry may have operated if either of the following conditions are noticed:

- No sound is heard when the power is turned on.
- Sound stops during a performance.

The function of this circuitry is to prevent circuitry damage if, for example, the positive and negative speaker connection wires are "shorted", or if speaker systems with an impedance less than the indicated rated impedance of the amplifier are used.

■ BEFORE REPAIR AND ADJUSTMENT

Disconnect AC power, Discharge both Power Supply Capacitors C541 and C542 through a 10Ω, 5W resistor to ground.

DO NOT SHORT-CIRCUIT DIRECTLY (with a screwdriver blade, for instance), as this may destroy solid state devices.

After repairs are completed, restore power gradually using a variac, to avoid overcurrent.

Current consumption at 230V, 50 Hz in NO SIGNAL mode should be less than 350mA.

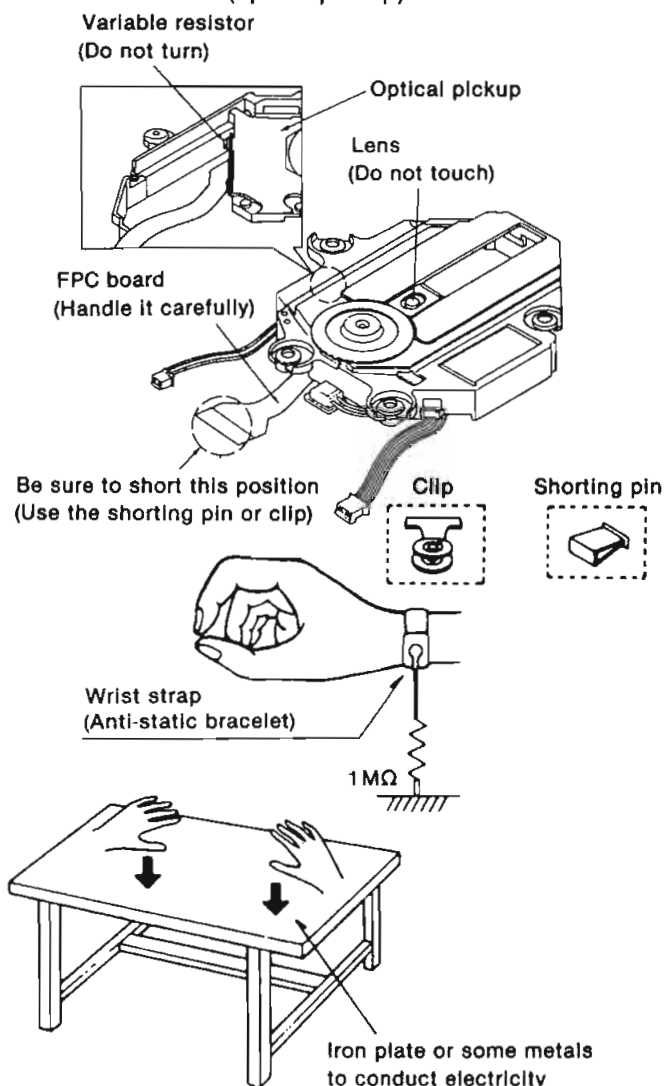

if this occurs, follow the procedure outlines below:

1. Turn off the power.
2. Determine the cause of the problem and correct it.
3. Turn on the power once again after one minute.

Note:

When the protection circuitry functions, the unit will not operate unless the power is first turned off and then on again.

FRONT PANEL CONTROLS AND FUNCTIONS

The functions indicated by the numbers with black background (for example ③) can also be activated from the remote control transmitter.

Tuner

Tuner control

- ① **Timer play button (PLAY TIMER)**
Use for timer play (when you want play to begin automatically at a preset time).
- ② **Timer recording button (REC TIMER)**
Use for timer recording (when you want to begin recording automatically at a preset time).
- ③ **Cancel button (CANCEL)**
Press to cancel the contents chosen with the jog dial.
- ④ **Set button (SET)**
Press to set various functions.
- ⑤ **Display select button (DISPLAY)**
Press to select the display (mode display, clock, tape counter, etc.).
- ⑥ **Clock/timer button (CLOCK/TIMER)**
Use to select the desired timer mode or to adjust the clock.
- ⑦ **Sleep timer button (SLEEP)**
Press when you want the system to turn itself off.
- ⑧ **Compact disc edit-recording mode select button (CD EDIT)**
Press to select the desired edit-recording mode.
- ⑨ **Tuning mode select button (TUNING)**
Press to select the preset, manual or auto tuning mode.
- ⑩ **Band select button (BAND)**
Press to select the LW, MW or FM radio band.
- ⑪ **FM mode/beat proof button (FM MODE/BP)**
Press to select the FM listening mode (stereo or monaural) during FM broadcasts or to reduce the unwanted beat signals (whistle) during recording of a LW/MW broadcast.
- ⑫ **Jog dial (AI JOG)**
Use to select the contents of the mode, i.e., select tracks in CD player mode or stations in the tuner mode, as well as many other functions.

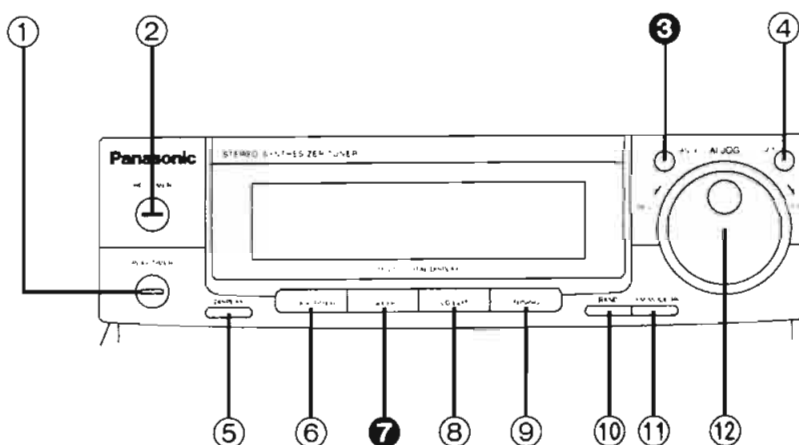

Multi digital display

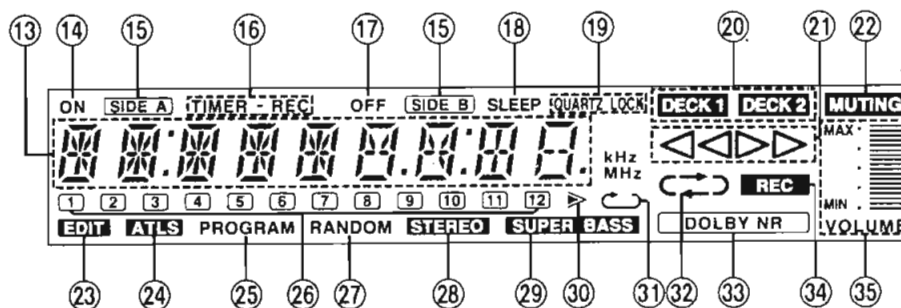

- ⑬ **Alphanumeric display**
Shows the selected source, present time, tape counter and the contents of the timer setting, received frequencies, CD edit-recording mode, volume level, etc.
- ⑭ **Timer on-time indicator (ON)**
Shows the timer on-time (the time the system is set to go on).
- ⑮ **Tape side indicator (SIDE A, B)**
Shows which side of the cassette tape (A or B) will be recorded on when you use the edit-recording of a compact disc.
- ⑯ **Timer recording indicator (TIMER REC)**
Lights when you press the timer recording button.
- ⑰ **Timer off-time indicator (OFF)**
Shows the timer off-time (the time the system is set to shut off).
- ⑱ **Sleep timer indicator (SLEEP)**
Lights when you press the sleep timer button.
- ⑲ **Quartz lock indicator (QUARTZ LOCK)**
Lights when you precisely tune in a broadcast station.
- ⑳ **Deck 1/deck 2 indicator (DECK 1, DECK 2)**
Lights to show which deck is operational (deck 1 or deck 2).
- ㉑ **Tape direction indicators (◀, ▶)**
Shows the direction of tape travel.
- ㉒ **Muting indicator (MUTING)**
Lights when you activate the muting mode.
- ㉓ **Compact disc edit-recording indicator (EDIT)**
Lights when you use the edit-recording from a compact disc.
- ㉔ **Automatic tape level setting indicator (ATLS)**
Lights when you use ATLS recording.
- ㉕ **Program indicator (PROGRAM)**
Lights during the program play mode of the compact disc.
- ㉖ **Matrix display (1–12)**
Shows the number of tracks and preset channels.
- ㉗ **Random play indicator (RANDOM)**
Lights during the random play mode of the compact disc.
- ㉘ **FM stereo indicator (STEREO)**
Lights when you receive an FM stereo broadcast. It will not light if you are using the FM mode/beat proof button to select monaural mode.
- ㉙ **Super bass indicator (SUPER BASS)**
Lights when you activate the super bass mode.
- ㉚ **Over indicator (▶)**
Lights if there are 13 or more tracks on the disc.
- ㉛ **Repeat play indicator (↺)**
Lights during the repeat play mode of the compact disc.
- ㉜ **Reverse mode indicators (↵) (↶) (↷)**
Shows which of the reverse modes you selected with the reverse mode button.
- ㉝ **Dolby noise reduction indicator (DOLBY NR)**
Lights when you activate the Dolby noise reduction system.
- ㉞ **Recording indicator (REC)**
Lights when the system is in the recording (recording standby) mode.
- ㉟ **Volume level indicator**
Shows the volume level.

Amplifier

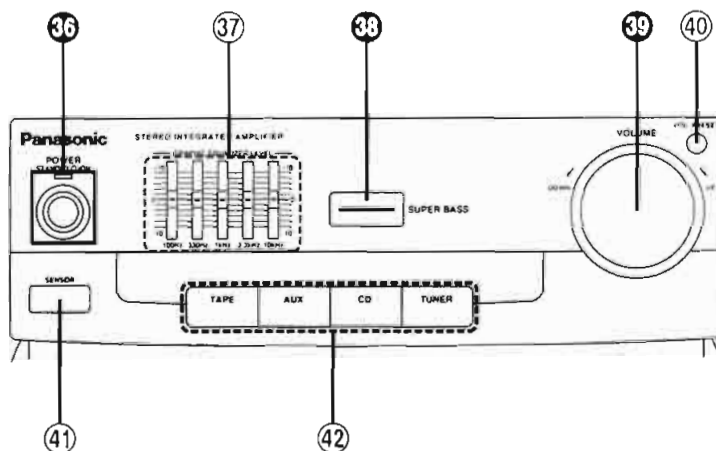

■ Amplifier controls

36 Power "STANDBY \odot /ON" switch and indicator (POWER STANDBY \odot /ON)

This switch switches ON and OFF the secondary circuit power only. The unit is in the "standby" condition when this switch is set to the STANDBY \odot position. Regardless of the switch setting, the primary circuit is always "live" as long as the power cord is connected to an electrical outlet.

- The indicator will illuminate when the unit is in "STANDBY" condition.

37 Equalizer controls (GRAPHIC EQUALIZER LEVEL)

Use to adjust the equalization level.

These controls are for compensation of tonal quality. By sliding the controls at each of the indicated frequencies in the "+" direction, the tonal quality is increased, and by sliding them in the "-" direction, the tonal quality is decreased.

38 Super bass button (SUPER BASS)

Press to boost the dynamic low-frequency ranges.

39 Volume level control (VOLUME)

Turn to adjust the volume level.

When turning the control, the alphanumeric display shows the volume level.

Note that --- dB is the lowest volume setting and 0 dB is the highest.

40 Volume preset button (VOL PRESET)

Use to preset volume for timer play.

41 Remote control signal sensor (SENSOR)

Receives the signals from the remote control.

42 Input select buttons (TAPE, AUX, CD, TUNER)

Press to select the sound source.

Cassette deck

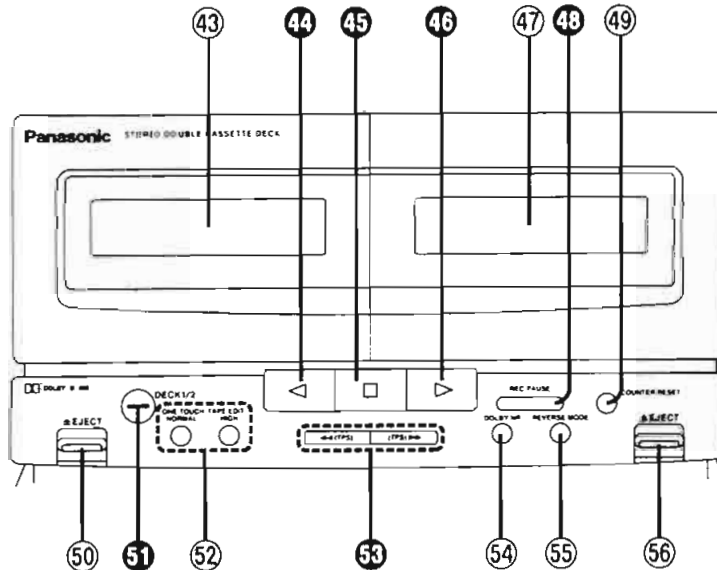

43 Deck 1 cassette holder

44 Reverse-side playback button (\triangleleft)

Press to start the playback or recording (deck 2) in the reverse direction.

45 Stop button (\square)

Press to stop the tape.

46 Forward-side playback button (\triangleright)

Press to start the playback or recording (deck 2) in the forward direction.

47 Deck 2 cassette holder

48 Record/record standby button (REC PAUSE)

Press to put deck 2 into the record standby mode.

49 Tape counter reset button (COUNTER RESET)

Press to reset the tape counter indicator to 000.

50 Deck 1 cassette eject button (\blacktriangle EJECT)

Press to open the deck 1 cassette holder.

51 Deck 1/deck 2 select button (DECK 1/2)

Press to select the deck to be operated.

52 One-touch tape edit buttons (ONE TOUCH TAPE EDIT)

Press to start the tape-to-tape recording.

53 Fast-forward/rewind/tape program sensor (TPS) buttons [\ll (TPS), (TPS) \gg]

Press to advance or rewind the tape, or to quickly search for the beginning of a track while the tape is being played.

54 Dolby noise reduction button (DOLBY NR)

Use to reduce the hissing noise heard from the tape. This system has the Dolby B-type noise reduction system.

55 Reverse mode select button (REVERSE MODE)

Press to select the reverse mode (for playback and recording).

56 Deck 2 cassette eject button (\blacktriangle EJECT)

Press to open the deck 2 cassette holder.

Compact disc player

- ⑤7 **Disc tray**
- ⑤8 **Stop button (□)**
Press to stop the disc play.
- ⑤9 **Disc tray open/close button (▲ OPEN/CLOSE)**
Press to open and close the disc tray.
- ⑥0 **Play button (▷)**
Press to start disc play.
- ⑥1 **Headphones jack (PHONES)**
Plug headphones cord into this jack.
- ⑥2 **Skip/search buttons (◀◀/◀◀•▶▶/▶▶)**
Press to move forward or backward through the tracks on a disc, or to hear disc sound at high speed while searching in the play mode.
- ⑥3 **Pause button (||)**
Press to stop the disc play temporarily.

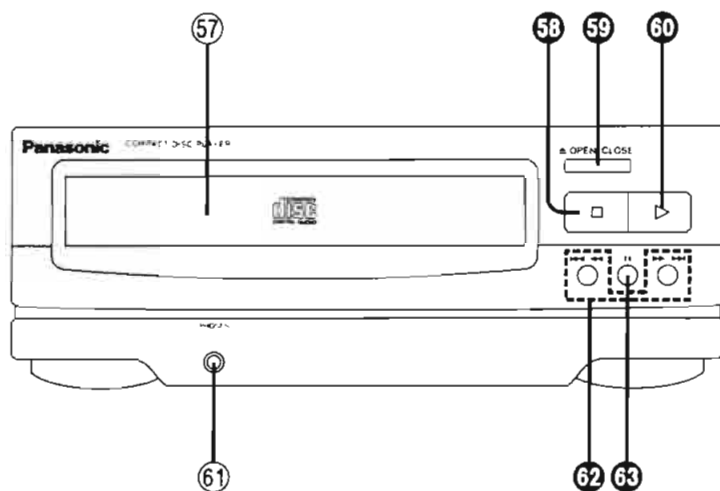

Common operation controls

The function description of buttons ③⑥, ③⑧ and ③⑨ is as described under "Amplifier controls"

- ⑥4 **CD input select button (CD)**
Press to select the CD source.
- ⑥5 **Tuner input select button (TUNER/BAND)**
Press to select the tuner source.
- ⑥6 **Muting button (MUTING -20 dB)**
Press to temporarily attenuate (mute) the volume level.

Tuner controls

The function description of buttons ③ and ⑦ is as described under "Tuner control"

- ⑥7 **Preset-tuning buttons (1-10/0)**
Press to select the preset channel of the tuner.

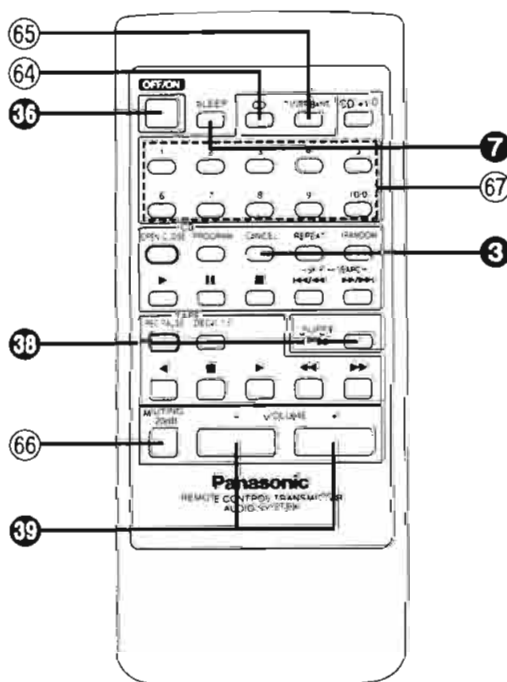

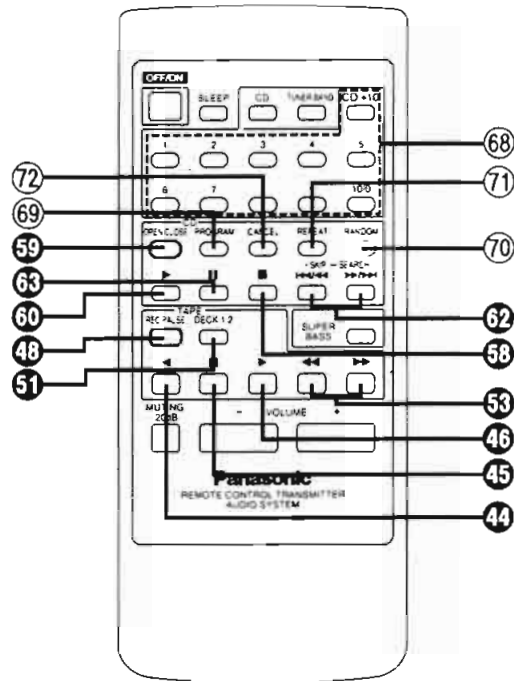

Compact disc controls

The function description of buttons 59, 69, 60, 62 and 53 is as described under "Compact disc player"

68 Numeric buttons (1-10/0, +10)
Use to specify the compact disc's track.

69 Program button (PROGRAM)
Press to activate the program play mode. You can then enter specific tracks using the numeric buttons.

70 Random button (RANDOM)
Press to play the disc's tracks in random order.

71 Repeat button (REPEAT)
Press to activate the repeat mode.

72 Cancel button (CANCEL)
Press to change the program.

Cassette deck controls

■ Cassette deck section

The function description of buttons 44, 45, 46, 48, 51 and 53 is as described under "Cassette deck"

DISASSEMBLY INSTRUCTIONS

"ATTENTION SERVICER"

Some chassis components may have sharp edges. Be careful when disassembling and servicing.

Ref. No.
1

Removal of the Cabinet

Procedure
1

- Remove the 13 screws (1 ~ 13).

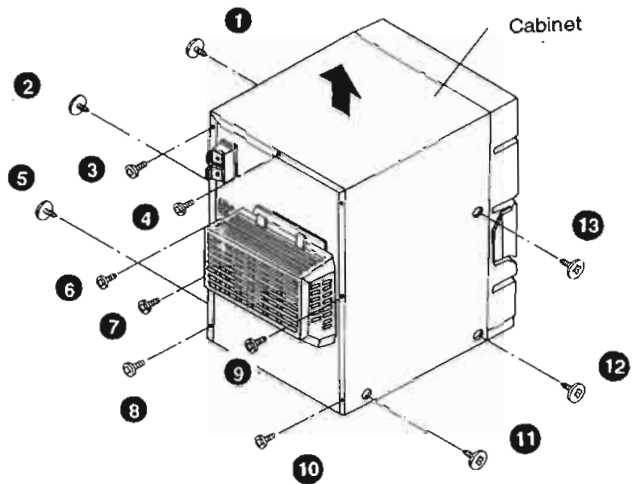

Ref. No.
2

Removal of the Front Cabinet

Procedure
1 → 2

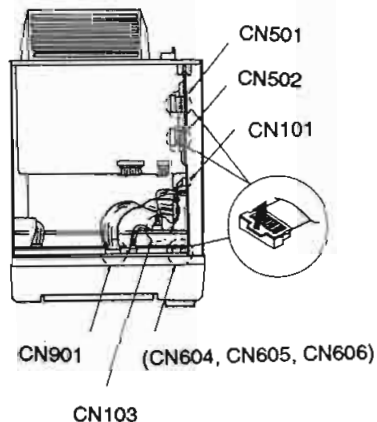

- Remove 2 flat cable (CN103, CN901).
- Remove 3 connectors (CN604, CN605, CN606).

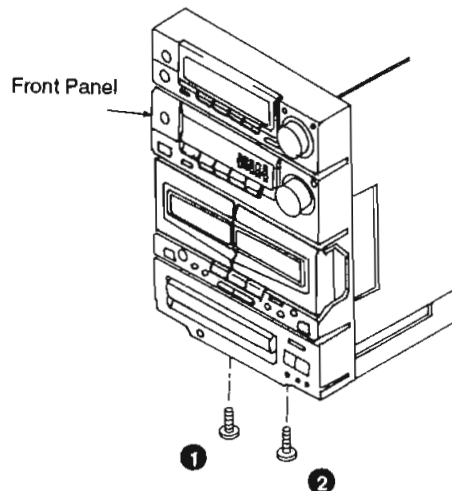

- Remove 2 screws (1, 2).

Ref. No.
3

Removal of the Main P.C.B.

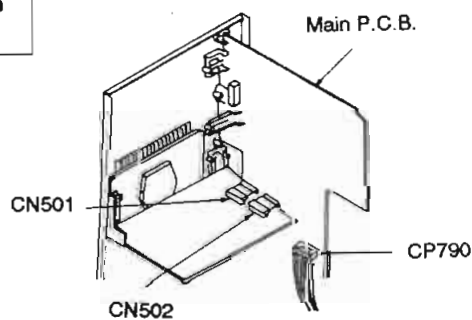

Procedure
1 → 2 → 3

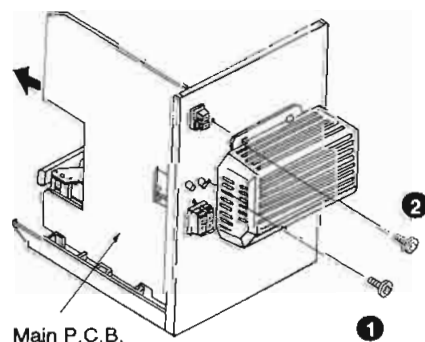

- Remove 3 connectors (CN501, CN502, CP790).

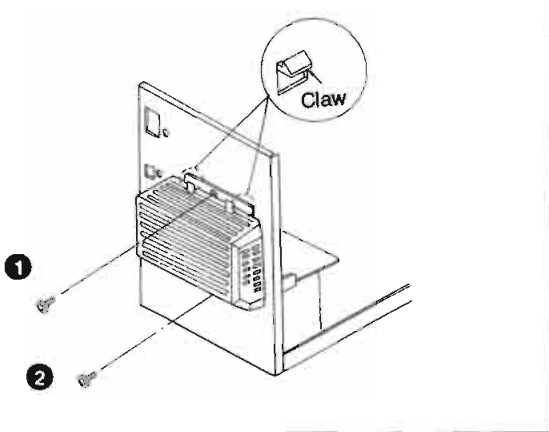
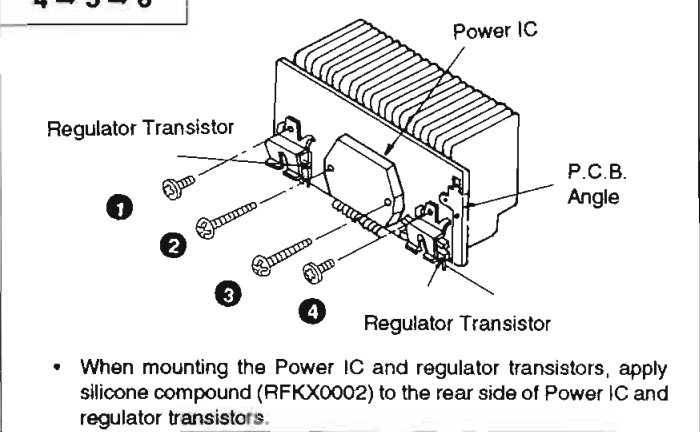

- Remove 2 screws (1 ~ 2).
- Remove the main P.C.B. in the direction of arrow.

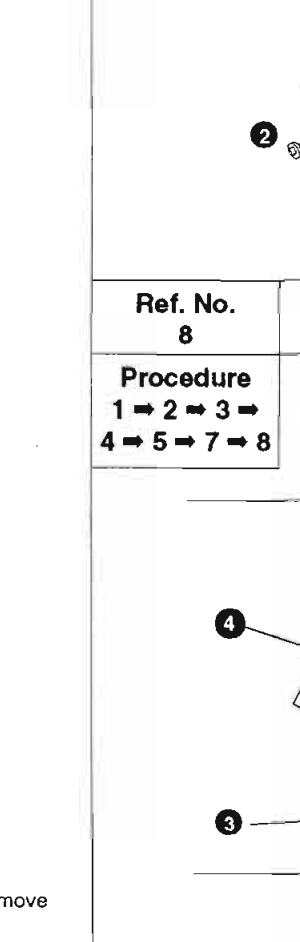
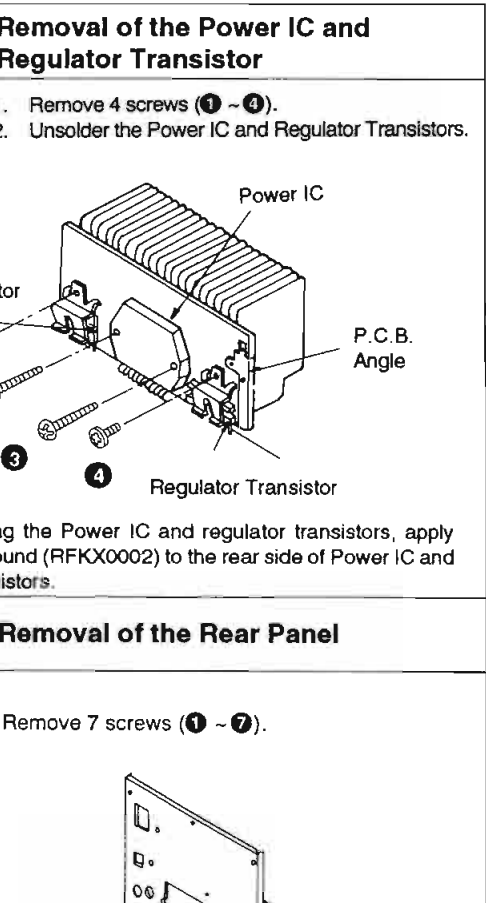
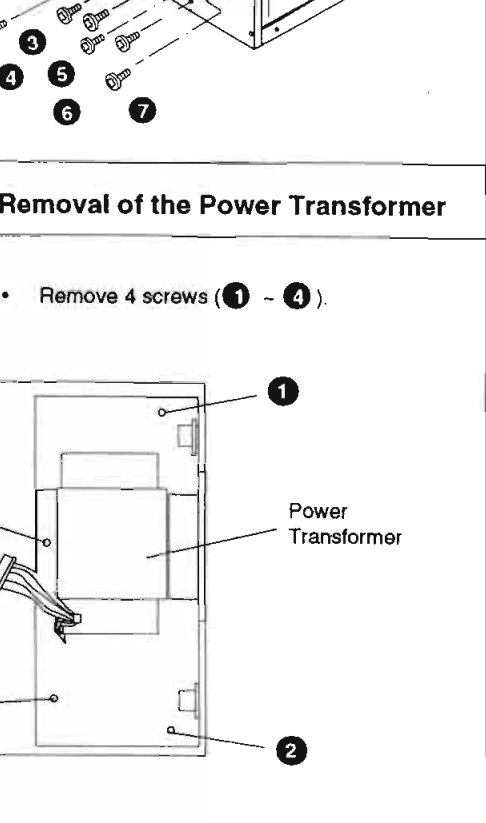
Ref. No. 4	Removal of the Heat Sink Cover	Ref. No. 6	Removal of the Power IC and Regulator Transistor
Procedure 1 → 4	<ol style="list-style-type: none"> 1. Remove 2 screws (1, 2). 2. Release 2 claws. 	Procedure 1 → 2 → 3 → 4 → 5 → 6	<ol style="list-style-type: none"> 1. Remove 4 screws (1 ~ 4). 2. Unsolder the Power IC and Regulator Transistors.
		 <ul style="list-style-type: none"> • When mounting the Power IC and regulator transistors, apply silicone compound (RFKX0002) to the rear side of Power IC and regulator transistors. 	
Ref. No. 5	Removal of the Power Amp. P.C.B.	Ref. No. 7	Removal of the Rear Panel
Procedure 1 → 2 → 3 → 4 → 5		Procedure 1 → 2 → 3 → 4 → 5 → 7	Remove 7 screws (1 ~ 7).
<ol style="list-style-type: none"> 1. Remove 3 screws (1 ~ 3). 			
 <ol style="list-style-type: none"> 2. Remove 2 connectors (CN504, CN505). 3. Push 3 claws in the direction of the arrow and then remove the Power Amp. P.C.B. 	Ref. No. 8	Removal of the Power Transformer <ul style="list-style-type: none"> • Remove 4 screws (1 ~ 4). 	

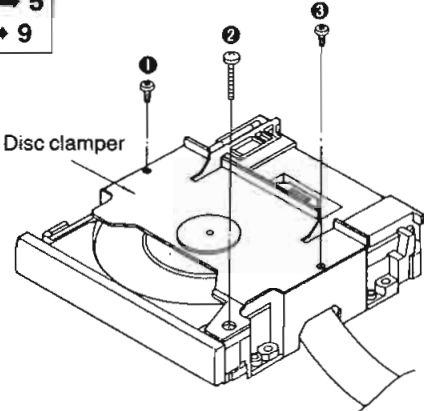
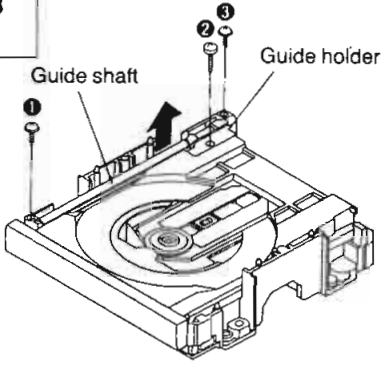
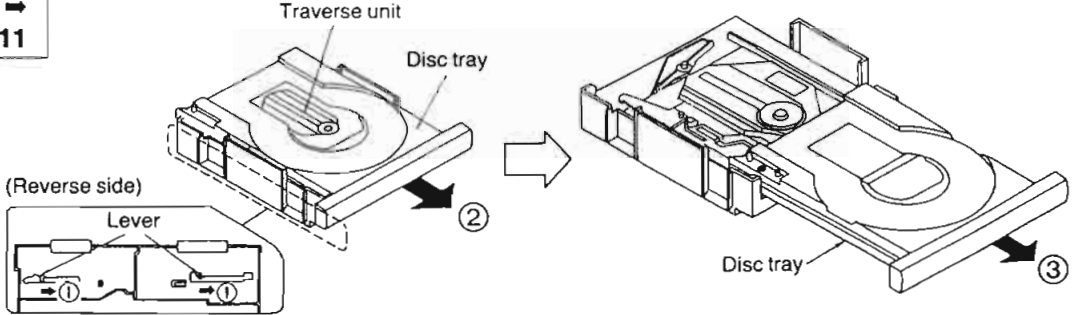
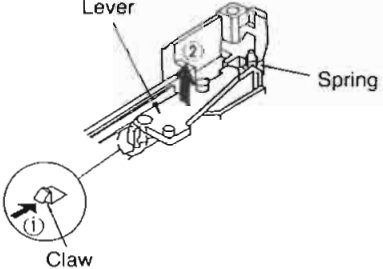
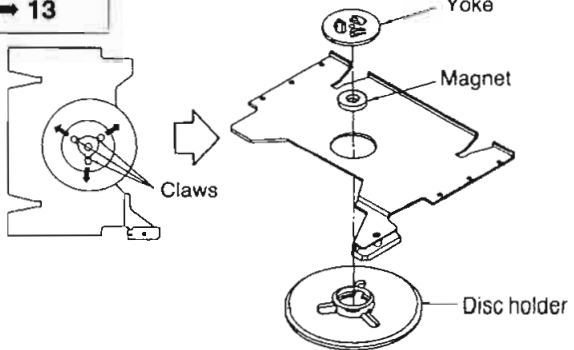
Ref. No. 9	Removal of Disc Clamper	Ref. No. 10	Removal of the Guide shaft and Guide Shaft Holder
Procedure 1 → 2 → 3 → 5 → 7 → 8 → 9	 <p>•Remove the 3 screws (①~③).</p>	Procedure 1 → 2 → 3 → 5 → 7 → 8 → 9 → 10	 <p>1. Remove the 3 screws (①~③). 2. Remove the guide shaft and guide shaft holder in the direction of the arrow.</p>
Ref. No. 11	Removal of the Disc Tray	 <p>1. Move the lever in the direction of arrow ① until the traverse unit goes down and the disc tray slightly in the direction of the ②.</p> <p>2. Remove the disc tray in the direction of the arrow ③.</p>	
Ref. No. 12	Removal of the Lever	Ref. No. 13	Removal of the Magnet and Holder
Procedure 1 → 2 → 3 → 5 → 7 → 8 → 9 → 10 → 11 → 12	 <p>1. Remove the spring. 2. Remove the claw in the direction of the arrow ① and then remove the lever in the direction of the arrow ②</p>	Procedure 1 → 2 → 3 → 5 → 7 → 8 → 9 → 13	 <p>•Remove the 3 claws.</p>

Ref. No. 14 **Removal of the Loading P.C.B. and Loading Motor**

Procedure
 1 → 2 → 3 →
 5 → 7 → 8 →
 9 → 10 → 11
 → 12 → 14

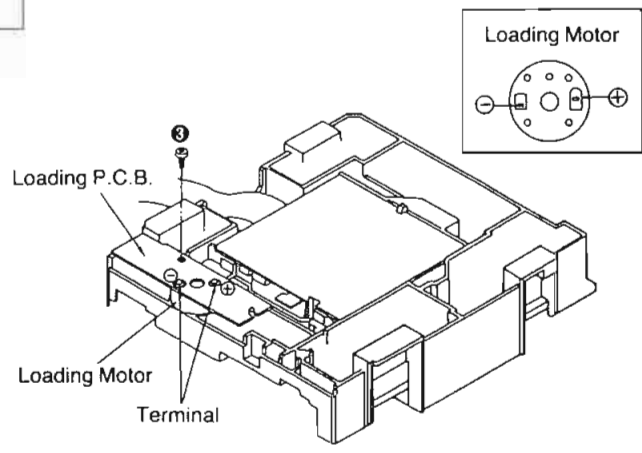
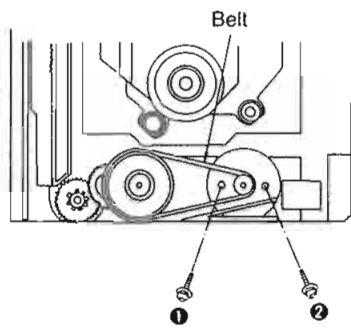

1. Remove the belt.
2. Remove the 2 screws (1~2).
3. Remove the screw (3).
4. Unsolder the 2 terminals of loading motor.

Ref. No. 15 **Removal of the Servo P.C.B.**

Procedure
 1 → 2 → 3 →
 5 → 7 → 8
 → 15

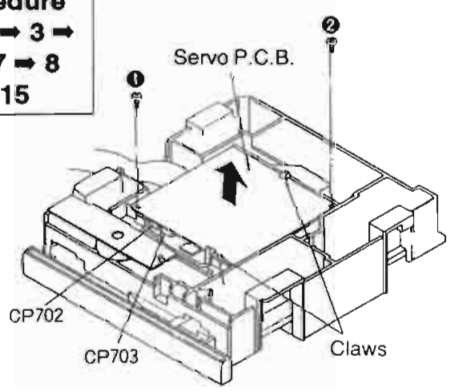

•Removal of the F.P.C. board
 Push the top of the connector in the direction of the arrow ①, and then Pull Out the flat cable in the direction of the arrow ②.

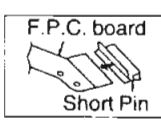

Note:
 Insert a short pin into the traverse deck's F.P.C. board.

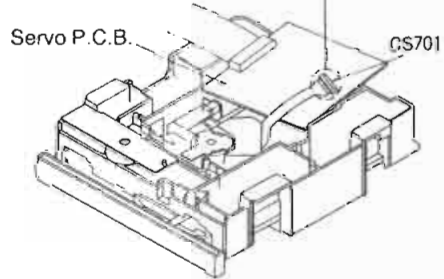

1. Remove the 2 screws (1, 2).
2. Remove the 2 claws.
3. Remove the servo P.C.B. in the direction of the arrow.
4. Remove the 2 connectors (CP702, CP703).
5. Remove the F.P.C. Board (CS701).

Ref. No. 16 **Removal of the Traverse Unit**

Procedure
 1 → 2 → 3 →
 5 → 7 → 8 →
 9 → 10 → 11
 → 12 → 14 →
 15 → 16

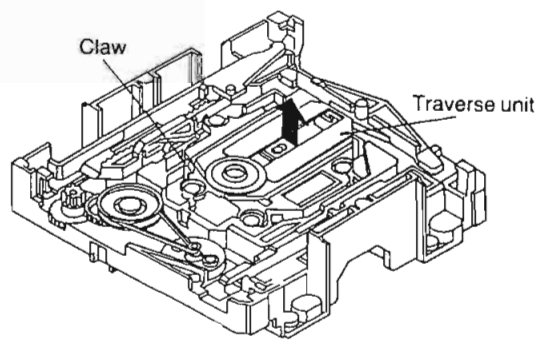
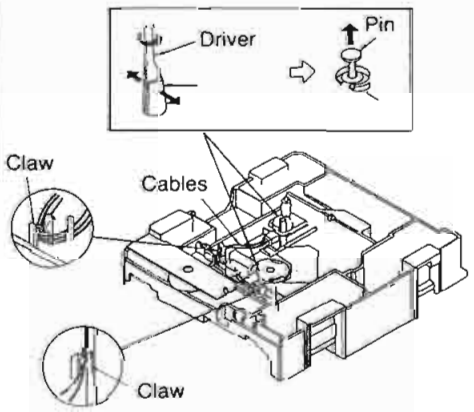

1. Release the cables from the code clammers.
2. Remove the 2 pin in the direction of the arrow.
3. Remove the claw and remove the traverse unit in the direction of the arrow.

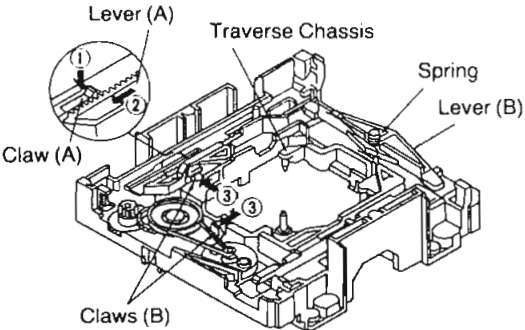
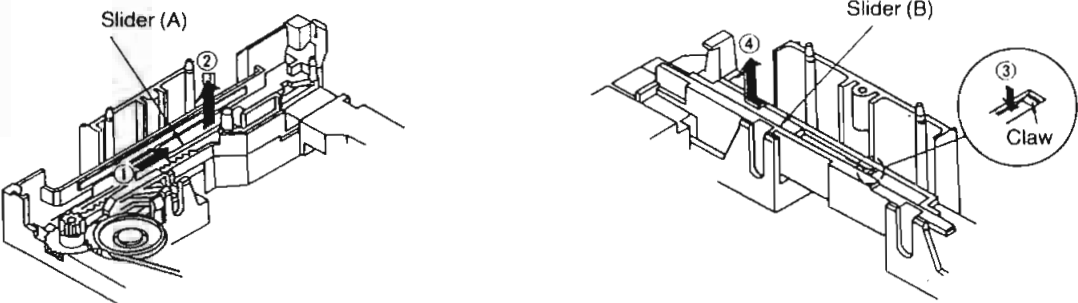
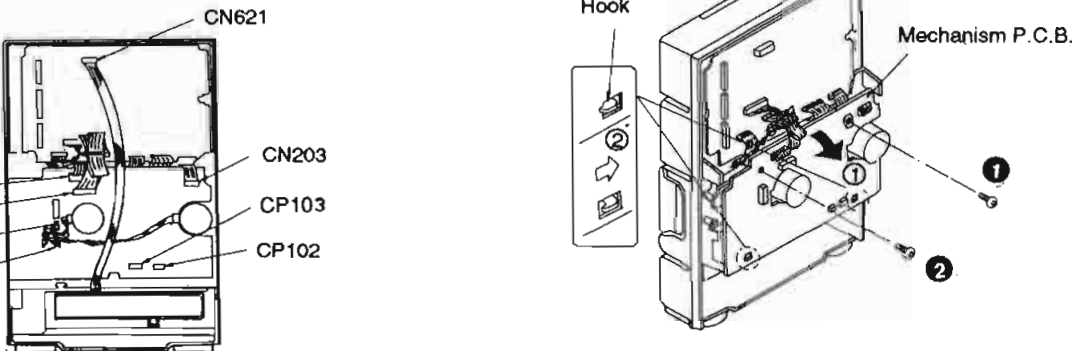
Ref. No. 17	Removal of the Traverse Chassis	
Procedure 1 ⇒ 2 ⇒ 3 ⇒ 5 ⇒ 7 ⇒ 8 ⇒ 9 ⇒ 10 ⇒ 11 ⇒ 12 ⇒ 14 ⇒ 15 ⇒ 16 ⇒ 17	<ul style="list-style-type: none"> ■ Remove the traverse chassis. <ol style="list-style-type: none"> 1. Push the claw (A) in the direction of arrow ①, and then move the slider (A) in the direction of the arrow ②. 2. Push 2 claws (B) in the direction of arrow ③, and then remove the traverse chassis. ■ Remove the lever (B) <ol style="list-style-type: none"> 1. Push the claw (A) in the direction of the arrow ①, and then move the lever (A) in the direction of the arrow ②. 2. Remove the spring. 3. Remove the lever (B) in the direction of the arrow ④. 	
Ref. No. 18	Removal of the Slider (A) and Slider (B)	<ul style="list-style-type: none"> ■ Removal of the Slider (A) <ul style="list-style-type: none"> ● Move the slider (A) in the direction of the arrow ①, and remove the slider (A) in the direction of the arrow ②. ■ Removal of the slider (B) <ul style="list-style-type: none"> ● Push the claw in the direction of the arrow ③, and remove the slider (B) in the direction of the arrow ④.
Ref. No. 19	Removal of the Mechanism Control P.C.B.	
Procedure 1 ⇒ 2 ⇒ 19	<ol style="list-style-type: none"> 1. Remove the 2 connectors (CP103, CP102). 2. Remove 4 flat cables (CN203, CN204, CN205, CN621). 3. Unsolder 2 wires (W201, W202). 4. Remove 2 screws ①, ②. 5. Remove the Mechanism control P.C.B. in the direction of the arrow ①. 6. Push the P.C.B. from the hooks in the direction of the arrow ②. 	

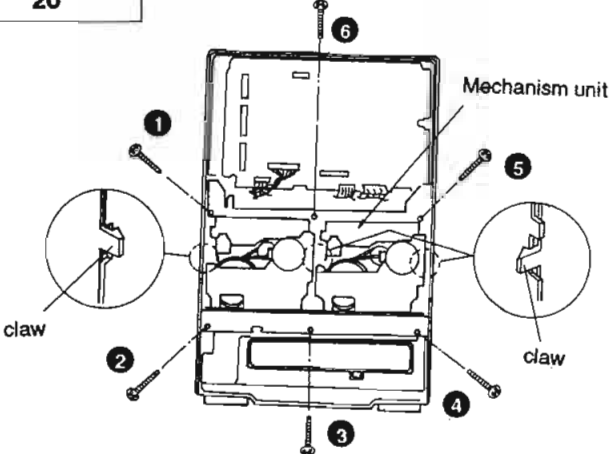
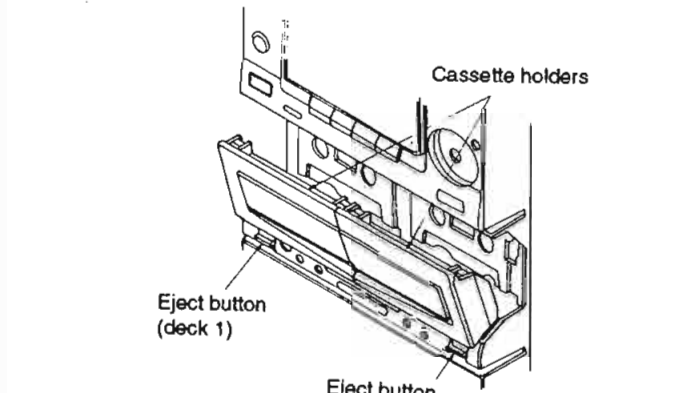
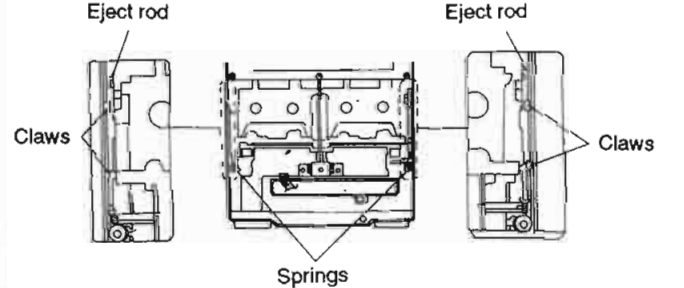
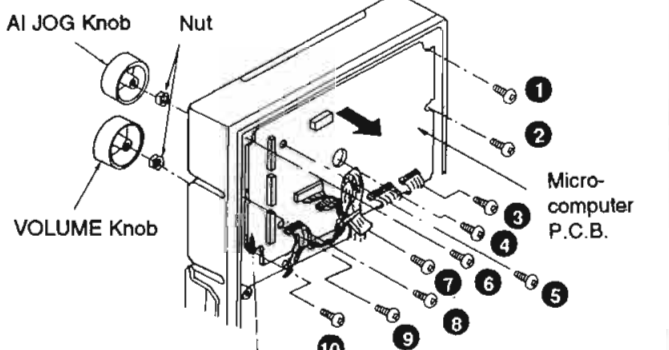
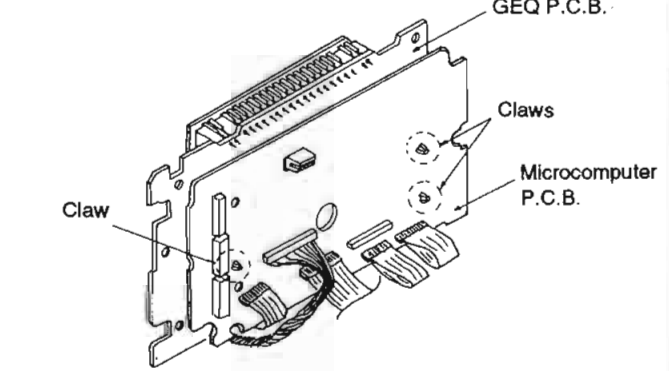
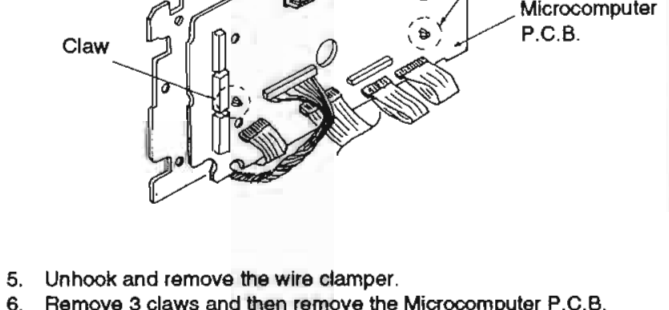
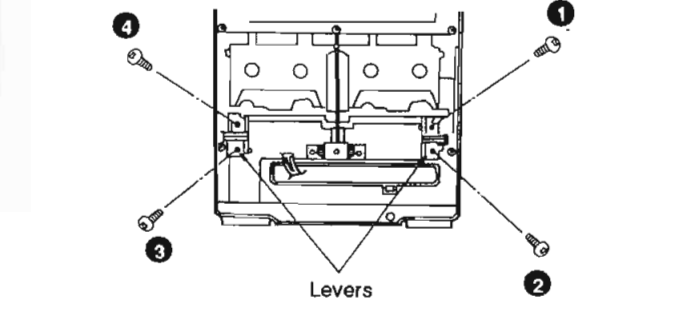
Ref. No. 20	Removal of the Mechanism Unit	Ref. No. 22	Removal of the Eject rod (Deck 1 & Deck 2).
Procedure 1 → 2 → 19 → 20	<ol style="list-style-type: none"> 1. Remove 6 screws (① - ⑥). 2. Remove 2 claws. 	Procedure 1 → 2 → 19 → 22	<ol style="list-style-type: none"> 1. Press the eject buttons (Deck 1 & Deck 2).
			
Ref. No. 21	Removal of the GEQ P.C.B. and Micro-computer P.C.B.	 <ol style="list-style-type: none"> 2. Remove 2 springs (Deck 1 & Deck 2). 3. Remove the 4 claws and then remove the eject rods. 	
Procedure 1 → 2 → 19 → 20 → 21	<ol style="list-style-type: none"> 1. Pull out the 2 knobs (volume and AI JOG knobs). 2. Remove the 2 nuts. 3. Remove 10 screws (① ~ ⑩). 4. Remove the GEQ P.C.B. and Microcomputer P.C.B. 	Ref. No. 23	
		Removal of the Eject levers (Deck 1 & Deck 2)	
 <ol style="list-style-type: none"> 5. Unhook and remove the wire clasper. 6. Remove 3 claws and then remove the Microcomputer P.C.B. 		Procedure 1 → 2 → 19 → 20 → 22 → 23	<ul style="list-style-type: none"> • Remove 4 screws (① - ④)
			

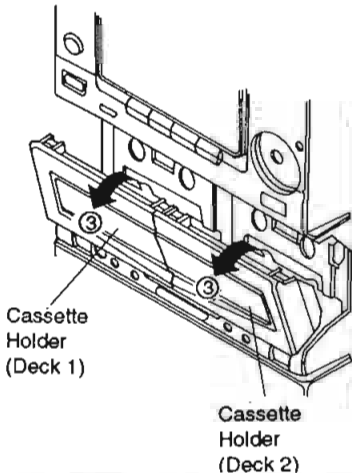
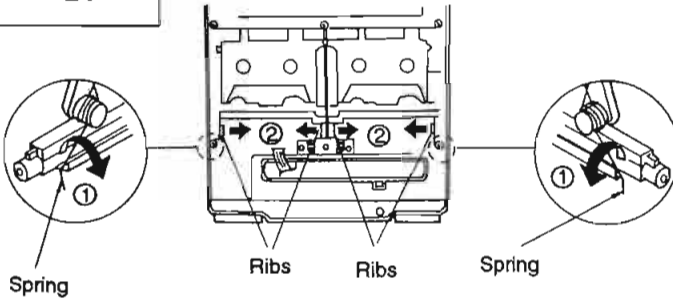
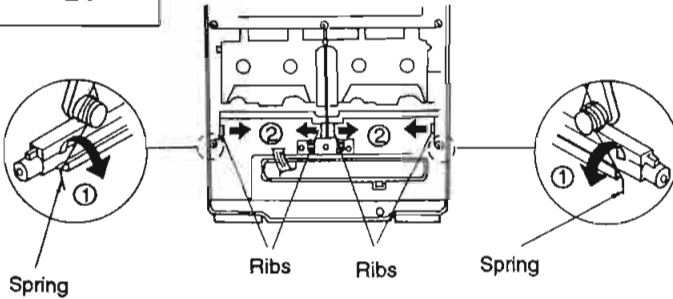
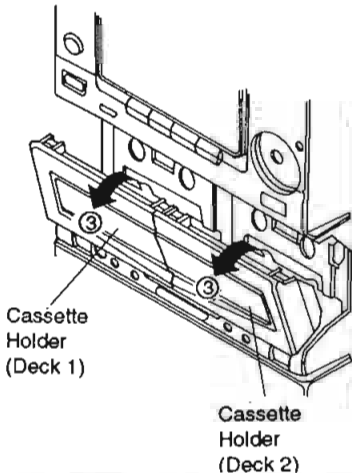
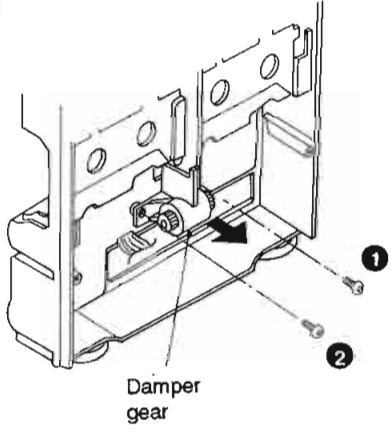
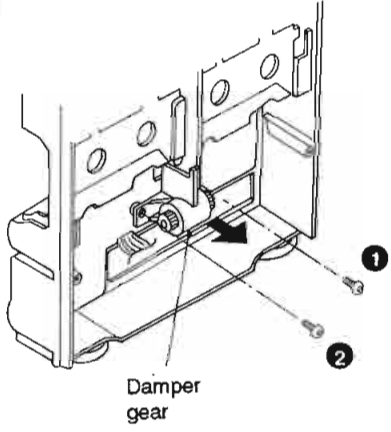
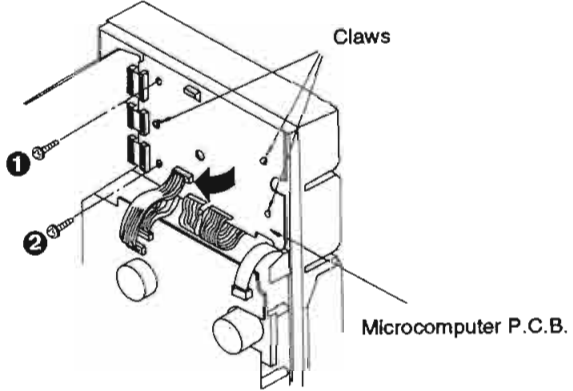
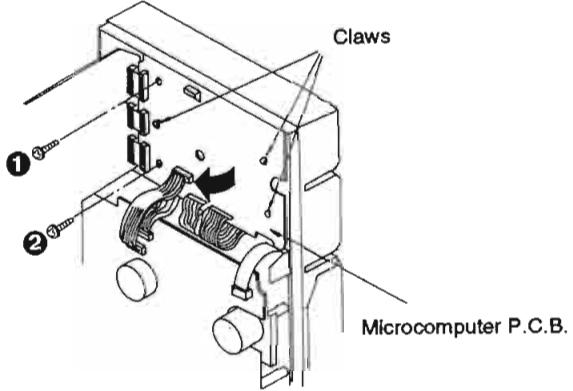
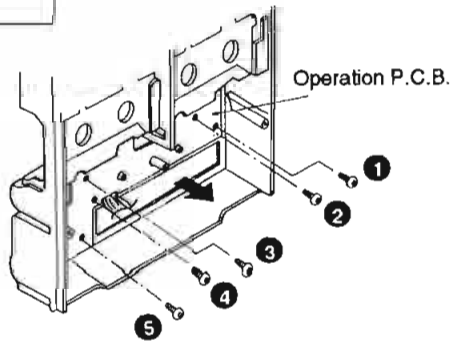
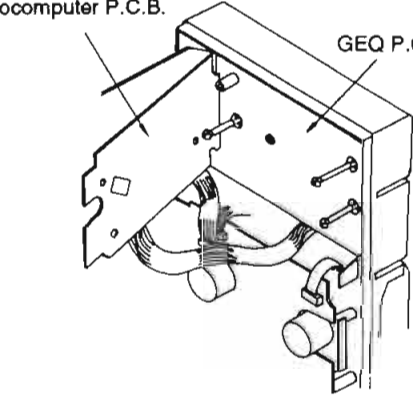
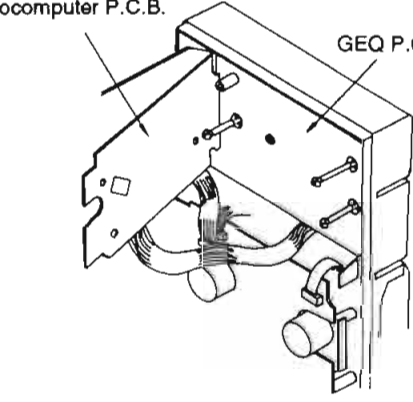
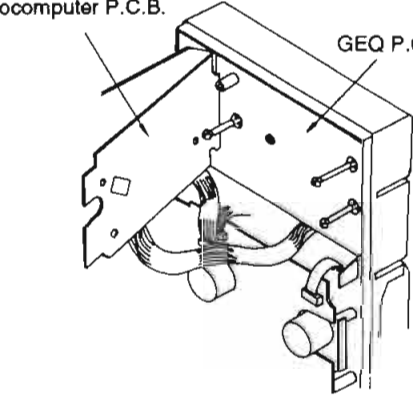
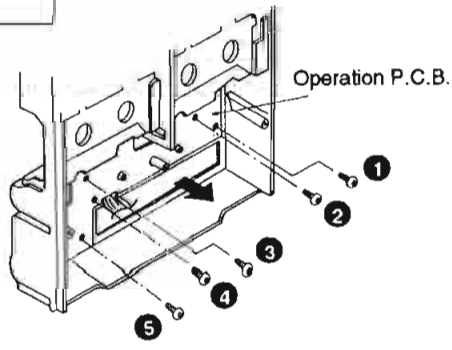
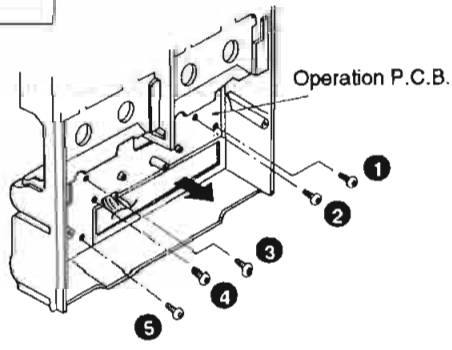
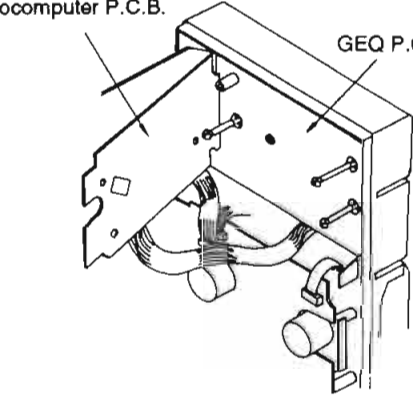
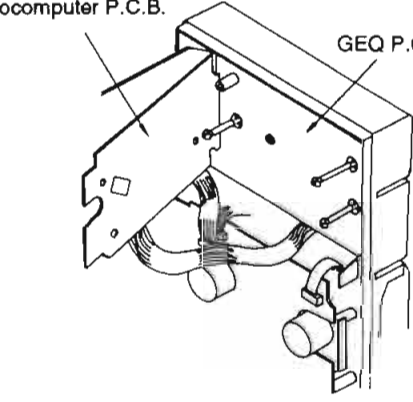
Ref. No. 24	Removal of the Cassette Holder (Deck 1 & Deck 2)	3. Remove the cassette holder in the direction of the arrows ③.	
Procedure 1 → 2 → 19 → 20 → 22 → 23 → 24	1. Remove 2 springs in the direction of the arrow ①. 2. Push the ribs in the direction of the arrows ②.		
			
Ref. No. 25	Removal of the Damper Gear	Ref. No. 27	How to check the GEQ P.C.B. and Microcomputer P.C.B.
Procedure 1 → 2 → 19 → 20 → 22 → 23 → 24 → 25	1. Remove 2 screws (①, ②). 2. Pull out the damper gear in the direction of the arrow.	Procedure 1 → 27	1. Remove 2 screws (①, ②). 2. Release 2 claws. 3. Move the Microcomputer P.C.B. in the direction of the arrow.
			
Ref. No. 26	Removal of the operation P.C.B. (Cassette Deck/CD)		
Procedure 1 → 2 → 19 → 20 → 22 → 23 → 24 → 25 → 26	1. Remove 5 screws (① ~ ⑤). 2. Remove the operation P.C.B. in the direction of the arrow.		
			
		4. When checking the soldered surface of the P.C.B. (GEQ and Microcomputer) and replace the parts, do as shown in the figure above.	

Ref. No.
28

How to check the Servo P.C.B.

Procedure

1 → 2 → 19 →
20 → 28

1. Remove the connector CP790.
2. Remove 4 screws (① ~ ④).

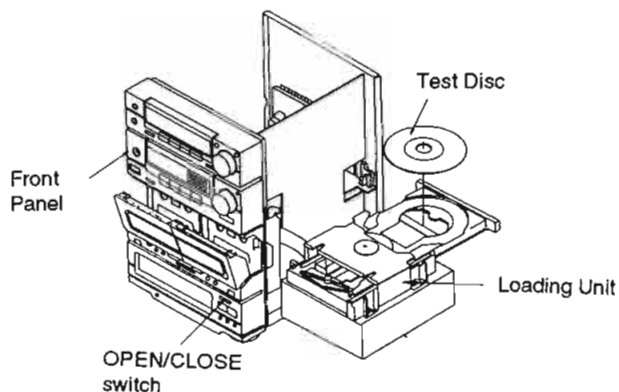
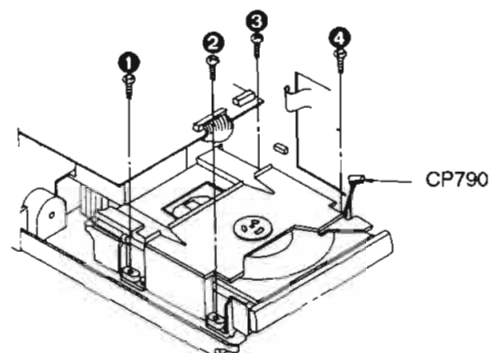

3. Reinstall the front panel to the body and reconnect all the flat cables and connectors.
4. Place the loading unit sideways as shown in figure.
5. Set the test disc.

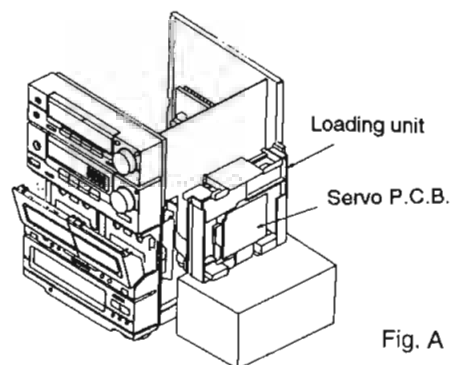

Fig. A

6. When checking the soldered side of the Servo P.C.B., do as shown in fig. A.

Ref. No.
29

How to check the Audio P.C.B.

Procedure

1 → 29

1. Place the Audio P.C.B. as shown in figure with all the flat cables and connectors connected.
2. When checking the soldered surface of the Audio P.C.B., do as shown in figure.

Note : Audio PCB can be checked by disconnect from main P.C.B.

3. Connect jumper wire between TP511 and TP535.
4. Apply a AF signal to TP515 (Lch) or TP513 (Rch) and TP514 (GND) by using a AF OSC.

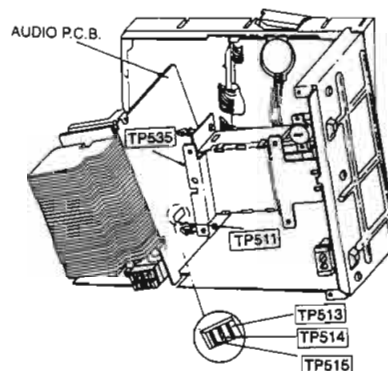

■ INSTALLING DISC TRAY

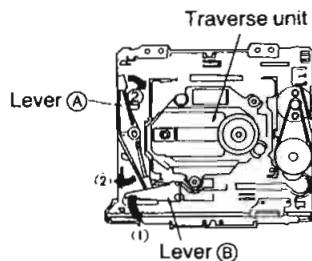

1. Move Lever B in the direction of arrow 1 and Lever A in the direction of arrow 2. (The traverse unit rises.)

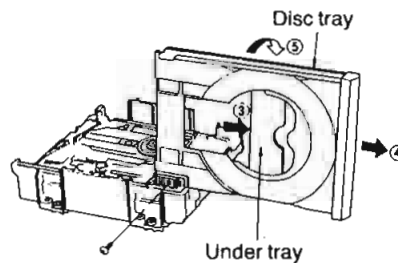

2. Screw the disc tray on the slider as shown above.
3. Slide the under tray fully in the direction of arrow 3.
4. Slide the disc tray fully in the direction of arrow 4.
5. Lay the disc tray down in the direction of arrow 5.

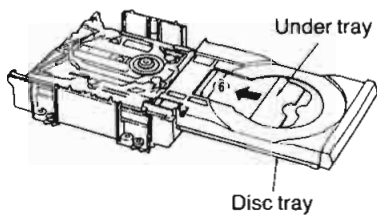

6. Slide the under tray in the direction of arrow 6.
7. Hold the disc tray and slide the under tray fully in the direction of arrow 6. (Slide but very little and the loading gear is engaged with disc tray gear.)

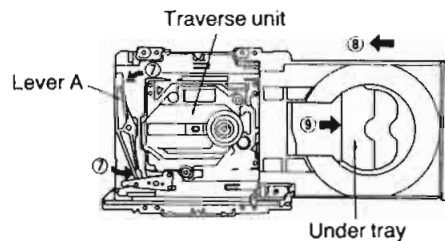

8. Move Lever A in the direction of arrow 7. (The traverse unit is lowered.)
9. Slide the disc tray in the direction of arrow 8. (Make sure that the under tray is moved in the direction of arrow 6.)

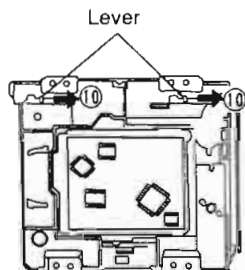

10. Slide the lever in the direction of arrow 10 and check if the traverse unit rises in the direction of arrow 11.

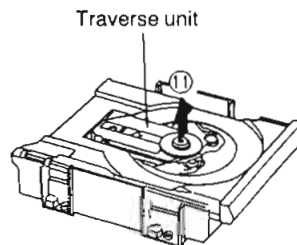

Ref. No.
30

How to check the Mechanism P.C.B.

Procedure 1 → 29

1. Set up the mechanism unit as shown in figure.
2. Remove 2 screws (① ~ ②).
3. Remove the Mechanism P.C.B. in the direction of arrow.

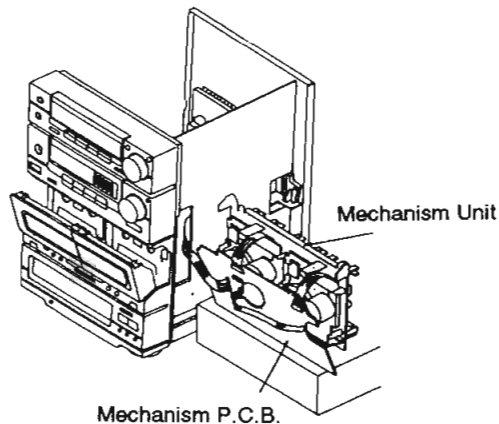
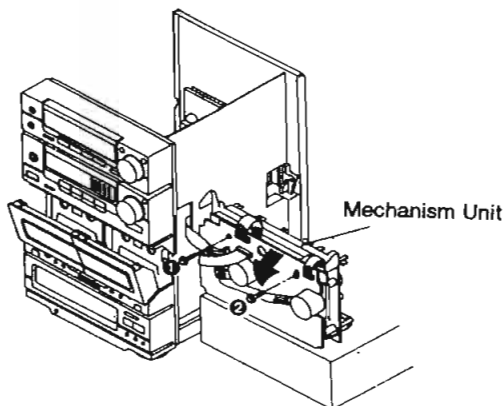

4. When checking the soldered surface of the mechanism P.C.B., do as shown in the figure.

CD UNIT ASSEMBLY

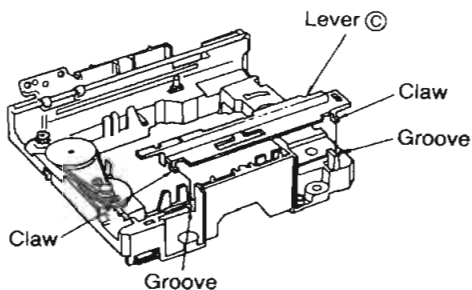

1. Install Lever ③ on the chassis by fitting the claws of Lever ③ in the two grooves of the chassis.

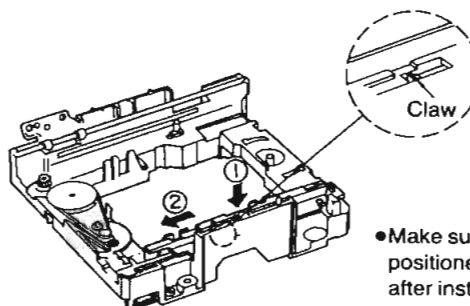

2. Slide Lever ③ in the direction of arrow ② while keeping it held down lightly in the direction of arrow ①.

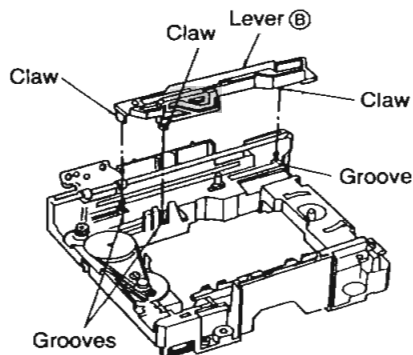

3. Install Lever ④ on the chassis by fitting the claws of Lever ④ in the three grooves of the chassis as shown above.

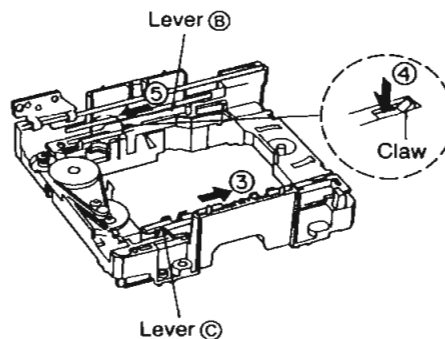

4. Slide Lever ④ fully in the direction of arrow ③.
5. Keep holding down the claw in the direction of arrow ④ and slide Lever ④ in the direction of arrow ⑤ to stop. (Slide but very little.)

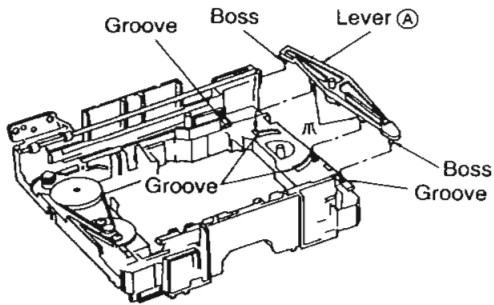

6. Install Lever (A) on the chassis by fitting the two claws of Lever (A) in the two grooves of the chassis and the two bosses in the two grooves as shown above.

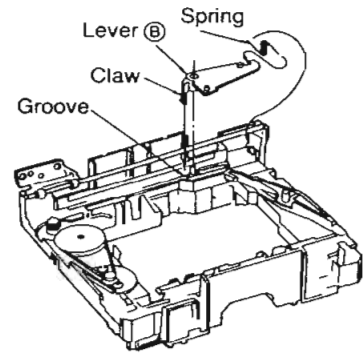

7. Install Lever (B) on the chassis by fitting the claw of Lever (B) in the groove of the chassis.
8. Install the spring on Lever (B) and the chassis.

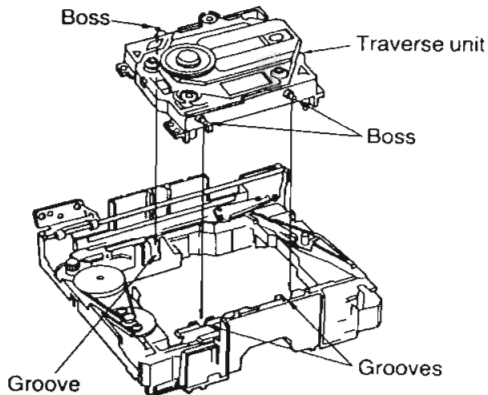

9. Install the traverse unit on the chassis by fitting the three bosses of the traverse unit in the three grooves of the chassis.

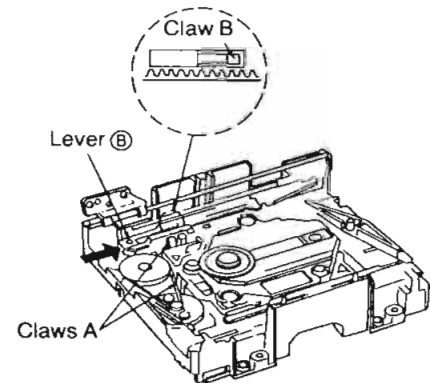

10. Make sure that the traverse unit is engaged with the two claws (A).
11. Slide Lever (B) in the direction of the arrow. Be sure to check if claw (B) is set as shown above. (Slide Lever (B) but very little.)

■ INSTALLING DISC TRAY UNIT

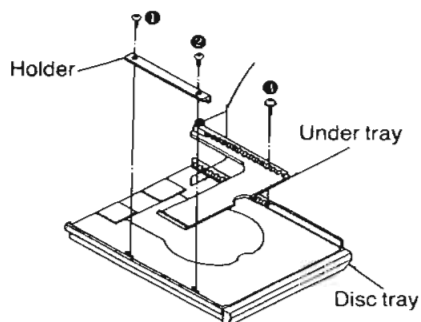

1. Install the under tray on the disc tray.
2. Install the holder on the disc tray with the two screws ① and ②.
3. Screw the under tray on the disc tray ③. Make sure that the under tray moves smoothly after installing the disc tray unit.

MEASUREMENTS AND ADJUSTMENTS

Warning : This product uses a laser diode. Refer to caution statements on page 3.

Caution : It is very dangerous to look or touch the laser beam. (laser radiation is invisible)
With the unit turned "on", laser radiation is emitted from the pickup lens.
Avoid exposure to the laser beam, especially when performing adjustments.

Measuring Instruments and Special Tools

- * Test discs
 1. Playability test disc (SZZP1054C).
 2. Uneven test disc (SZZP1056C).
- * Musical program disc (ordinary).
- * Extension cable kit (RFKZ0009).
- * Dual-beam oscilloscope with bandwidth of 30 MHz or better (with EXT. trigger and 1 : 1 probe).
- * Allen wrench (M2.0) (SZZP1101C).
- * Lock paint (RZZ0L01)

(1) MECHANICAL ADJUSTMENT

- When the traverse deck is replaced, making adjustments is not necessary. (The traverse deck ass'y is already adjusted.)
- Make adjustments to improve playability if the traverse deck has not been replaced.

1. Connect the oscilloscope's CH. 1 probe across **TP702** (RF) (+) and **TP703** (V-Ref.) (-) on the servo P.C.B.

Oscilloscope setting : VOLT200mV.
 SWEEP0.5 μ s.
 Input couplingAC.

2. Switch the player power ON, and play track 19 on the test disc (SZZ1056C).
3. Leave the player in play mode, and place the traverse deck as shown in Ref. No. 28 page 17.
4. Alternately adjust the two mechanical adjusting screws with the 2.0mm allen wrench (SZZP1101C) until the RF signal amplitude variation on the oscilloscope is minimized. (Refer to Fig. 2 on page 22)
5. After completing the adjustment, lock the **mechanical adjusting screws** with lock paint (RZZ0L01).

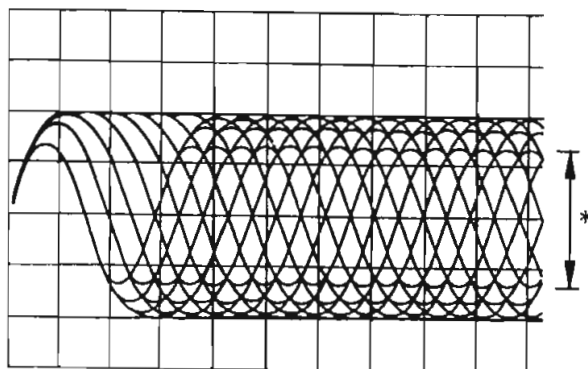

* Most stretched eye pattern

(2) BEST EYE (PD BALANCE) ADJUSTMENT

1. Connect the oscilloscope's CH. 1 probe across **TP702** (RF) (+) and **TP703** (V-Ref.) (-) on the servo P.C.B.

Oscilloscope setting: VOLT.....200mV
 SWEEP.....0.5 μ s.
 Input coupling AC.

2. Switch the player power ON, and play the 1 KHz (track 1) on the test disc (SZZP1054C).
3. Adjust VR701 until the vertical fluctuation of RF signal is minimized and the eye pattern is moststretched. (Refer to Fig. 1 on page 22)

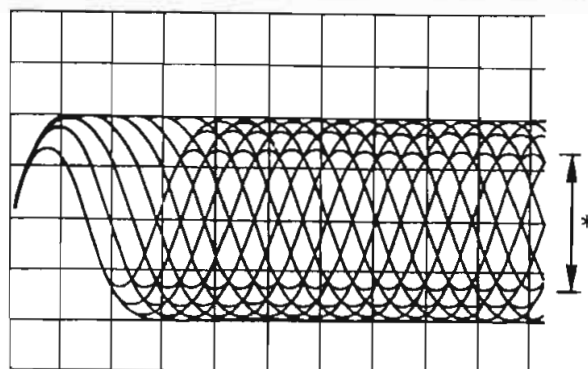

* Most stretched eye pattern

(3) CHECK OF PLAY OPERATION AFTER ADJUSTMENT

* Checking skip Search

1. Play an ordinary musical program disc.
2. Press the skip button to check for normal skip search operation (in both the forward and reverse directions).

* Checking Manual Search

1. Play an ordinary musical program disc.
2. Press the manual search button to check for smooth manual search operations at either low or high speed (in both the forward and reverse directions).

* Checking Playability

1. Play the 0.7mm black dot and the 0.7mm wedge on the test disc (SZZP1054C) and verify that no sound skip or noise occurs.
2. Play the middle tracks of the uneven test disc (SZZP1056C) and verify that no sound skip or noise occurs.

• CASSETTE DECK SECTION

(Please refer to fig. 4 for the adjustment point.)

MEASUREMENT CONDITION :

- Make sure heads are clean
- Make sure capstan and pressure roller are clean

TEST TAPE:

- Head azimuth adjustment (8 kHz, -20 dB): QZZCFM
- Tape speed adjustment (3 kHz, -10 dB): QZZCWAT
- Normal reference blank tape: QZZCRA
- CrO₂ reference blank tape: QZZCRX

HEAD AZIMUTH ADJUSTMENT (DECK 1, 2)

1. Playback the azimuth adjustment portion (8 kHz, -20 dB) of the test tape (QZZCFM). Vary the azimuth adjusting screw until the outputs of the L-ch and R-ch are maximized and the lisajous waveform, as illustrated, approaches 0 degrees.

Note:

If L-CH and R-CH are not maximized at the same point, adjust to the point where the levels of each channel are maximized and equal.

2. Perform the same adjustment in the play mode.
3. After the adjustment, apply screwlock to the azimuth adjusting screw.

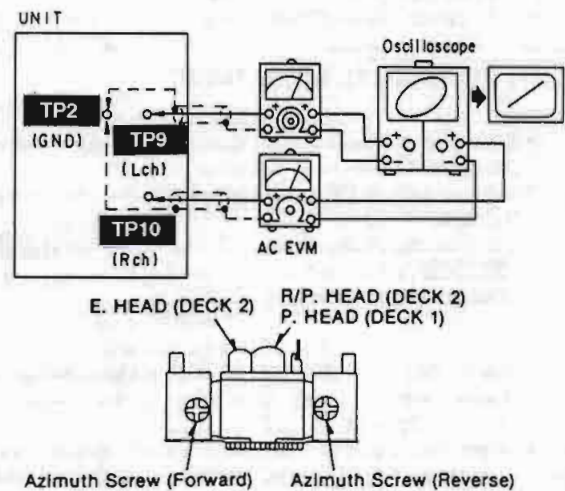

TAPE SPEED ADJUSTMENT (DECK 1, 2)

1. Test equipment connection is shown in figure.
2. Set the unit to "TAPE" position.
3. Playback the middle part of the test tape (QZZCWAT).
4. Adjust VR201 (DECK 1) and VR202 (DECK 2) so that the output is within the standard value.
5. Set the unit to "HIGH" position of editing speed button.
6. Adjust VR203 (DECK 2) so that the output is within the standard value.

Note:

1. The normal speed adjustment must be done before the High speed adjustment.
2. When adjusting the high speed, short circuit between TP1 and TP2.

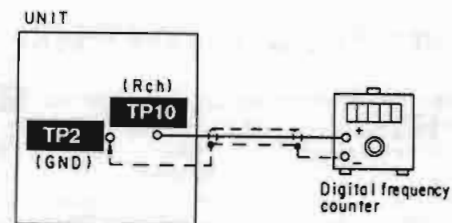

DECK 1 Standard value : 2995~3025 Hz (Normal)
DECK 2 Standard value : 2995~3025 Hz (Normal)

Standard value : 5100~5700 Hz (High)

PLAYBACK GAIN ADJUSTMENT (DECK 1, 2)

1. Test equipment connection is shown in figure.
2. Playback test tape (QZZCFM: 315Hz, -10dB).
3. Adjust VR101, VR102 (DECK 1) and VR103, VR104 (DECK 2) to read 390 ± 10 mV on the AC Electronic Voltmeter. (AC EVM)

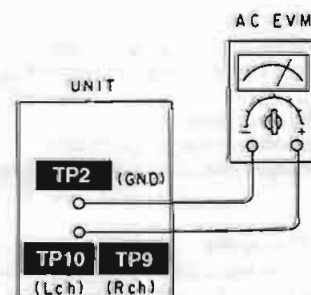

• Adjustment points

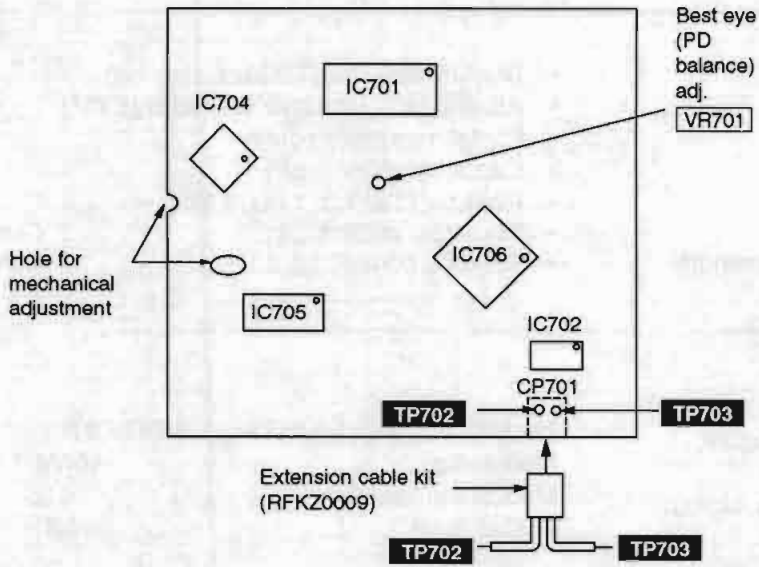

Fig. 1

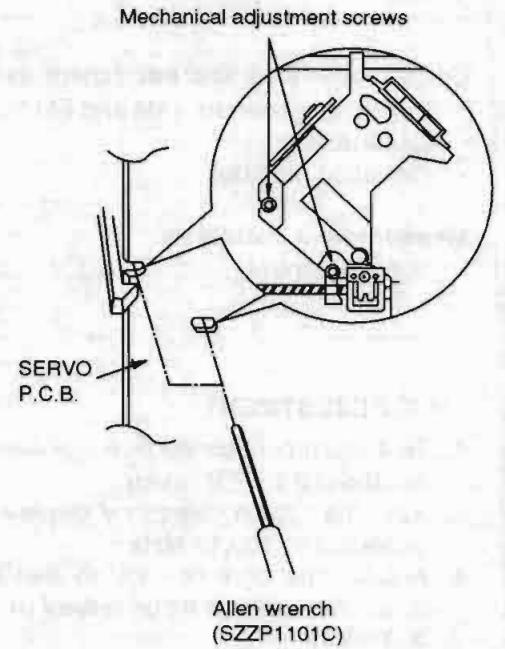

Fig. 2

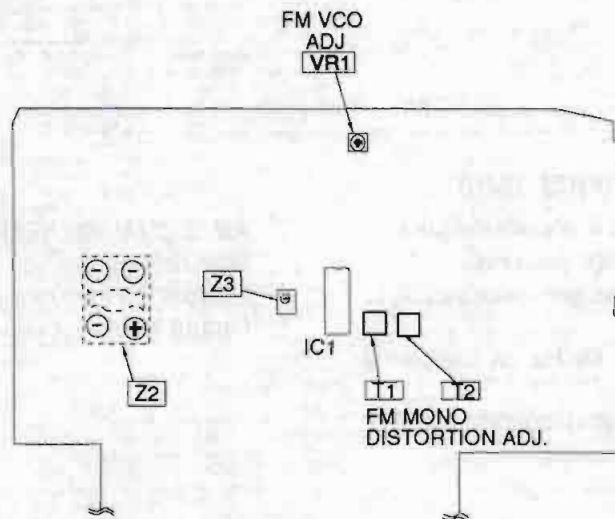

Fig. 3

• AM/FM TUNER SECTION

Note: For Z2 (AM IFT) and Z1 (AM ANT and OSC coil), they are supplied as adjusted parts.
So, do not turn the cores of the parts.

Control positions and equipment used

- FM signal generator (AM and FM-SG)
- Oscilloscope
- Distortion analyzer

Measurement condition

- Volume control.....Maximum

- Dummy antenna (75Ω unbalanced)
- AC and DC electronic voltmeter (EVM)
- Digital frequency counter
- Capacitor (50 V 1 μF)
- Resistor (330 kΩ, 1 kΩ, 1 MΩ)
- Equalizer control.....Center
- Balance control.....Center

FM IF ADJUSTMENT

1. Test equipment connection is shown in figure.
2. Set the unit to "FM" mode.
3. Set the radio frequency display and signal generator to **100.10 MHz**.
4. Adjust the core of **T1** so that the voltage measured in signal mode is **0mV (0 ±30mV)** in 300 mV range.
5. Adjust **T2** so that the distortion factor of L-ch is minimized.
6. Repeat steps 4 and 5.
7. Make sure that the distortion factors of L-ch and R-ch are nearly the same and minimum.

Note: The adjusting screwdriver used should be made of resin.

FM SIGNAL GENERATOR CONDITION

- Modulation.....100%
- Modulation frequency.....1 kHz
- Output level.....66dB

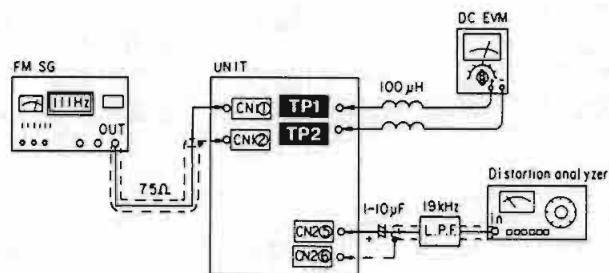

FM STEREO ADJUSTMENT (FREE RUN)

1. Test equipment connection is shown in figure.
2. Place unit into "FM STEREO" position.
3. Place the radio dial and signal generator setting to 98MHz.
4. Adjust **VR1** for **19 kHz ± 50 Hz** on frequency counter reading.
5. Tune a stereo broadcast and confirm the frequency stays at 19 kHz.

AM SIGNAL GENERATOR CONDITION

- Modulation.....30%
- Modulation frequency.....40%
- Output level.....66dB

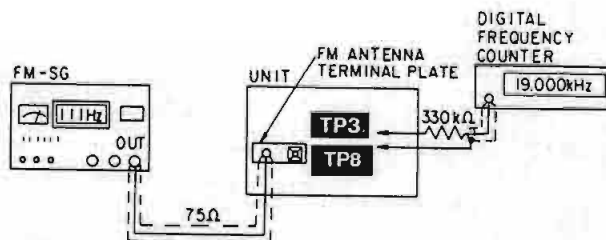

BIAS OSC FREQUENCY ADJUSTMENT (DECK 2)

1. Test equipment connection is shown in figure.
2. Set the unit to "TAPE" position.
3. Place cassette deck into **REC** mode.
4. Adjust **L201** for 99 ± 4 kHz on frequency counter reading.

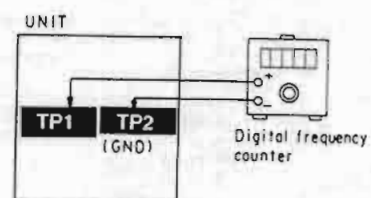

ERASE CURRENT CHECK (DECK 2)

1. Test equipment connection is shown in figure.
2. Insert the normal tape (QZZCRA).
3. Place cassette deck into **REC** mode.
4. Make sure that the output is within the standard value.
5. Insert the CrO₂ tape (QZZCRX).
6. Repeat steps 3, 4.

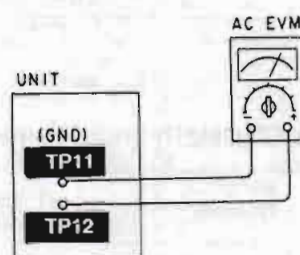

DECK 2 Standard value (Normal): more than mV
DECK 2 Standard value (CrO₂): more than 70 mV

• Cassette Deck Adjustment Point

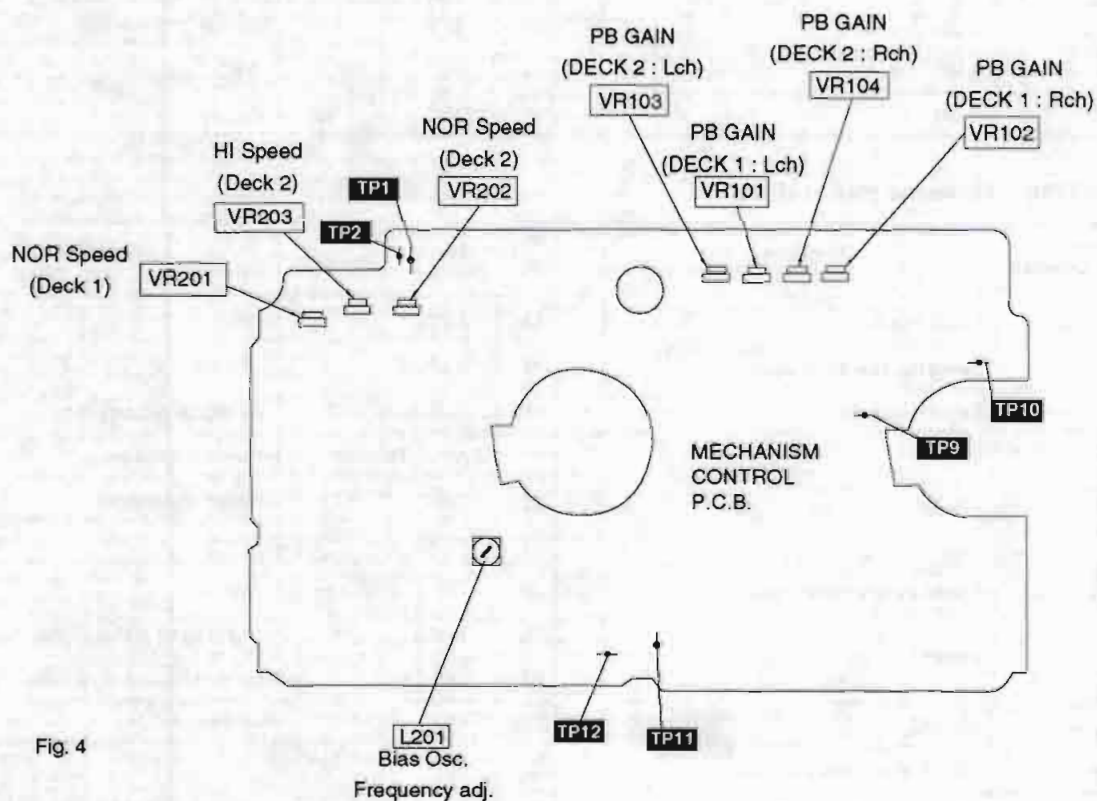

Fig. 4

■ TERMINAL FUNCTIONS OF IC

• IC105 (BU2040F-E2) : I/O Expander

Pin No.	Mark	I/O Division	Function
1	GND	—	GND
2	DATA	I	Data input
3	CLK	I	Clock input
4	TAPE	O	TAPE drive signal control
5	HI SPEED	O	HIGH speed drive signal control
6	DOLBY	I/O	DOLBY drive signal output
7	BP1	O	BEAT PROOF control (bit 1)
8	DMT	O	MUTING control signal output for deck sel.

Pin No.	Mark	I/O Division	Function
9	BP2	O	BEAT PROOF control (bit 2)
10	IH	O	Deck select control terminal
11	REC	O	REC drive signal control
12	2M	O	Motor speed control signal
13	3M	O	Motor speed control signal
14	2PL	O	Solenoid drive control signal
15	1PL	O	Solenoid drive control signal
16	VDD	I	+5V

• IC702 (TC0372DM2R) : Spindle motor drive

Pin No.	Mark	I/O Division	Function
1	GND	—	GND
2	NC	—	—
3	VOUT1	O	Spindle motor control
4	VCC	I	+7.5V
5	VOUT2	O	Spindle motor control
6	NC	—	GND
7	NC	—	GND
8	GND	—	GND

Pin No.	Mark	I/O Division	Function
9	GND	—	GND
10	NC	—	GND
11	-VIN2	I	Spindle motor control
12	+VIN2	I	Spindle motor control
13	+VIN1	I	Spindle motor control
14	-VIN1	I	Spindle motor control
15	NC	—	GND
16	GND	—	GND

• IC703 (AN8377N) : Traverse motor drive

Pin No.	Mark	I/O Division	Function
1	LRCK	I	Clock input
2	BLCK	I	Serial data bit clock input
3	SRDATA	I	Serial data input
4	COT1	—	Ground
5	COT2		
6	TEST		
7	VDD	I	Power supply (+5V input)
8	X2	—	Ground
9	X1		
10	VSS	—	Ground
11	AVDDL	I	Power supply (+5V input)
12	OUT.L	O	AF signal output (Lch)

Pin No.	Mark	I/O Division	Function
13	AVSS.L	—	Ground
14	AVSS.R	—	Ground
15	OUT.R	O	AF signal output (Rch)
16	AVDD.R	I	Power supply input
17	/RST	I	Reset signal input
18	PWM	—	—
19	TP	—	Ground
20	WVEL	I	High speed status signal input
21	DEMPH	I	De-emphasis signal input
22	CSEL	I	+5V input
23	192FS	—	—
24	768FS	O	Clock output (f=16.9344 MHz)

• IC701 (AN8800SCE2): Servo amp

Pin No.	Mark	I/O Division	Function
1	LDG	I	APC loop gain select
2	LDP	I	APC monitor PD polarity select
3	LD	O	Laser power auto control output
4	LPD	I	LD power monitor PD signal
5	GND	—	GND terminal
6	LDON	I	LD APC ON/OFF ("H": ON, "L" OFF)
7	AMPI	I	RF signal (X30 amp)
8	AMPO	O	
9	RF IN	I	RF AGC signal input
10	RF EQ	—	GND terminal
11	C. AGC	I	AGC detection capacitor input
12	ARF	O	RF signal output
13	C. SBDO	I	Dropout detection capacitor input
14	RF DET	O	RF detection signal ("L": detecting)
15	BDO	O	Dropout detection output
16	Vcc	I	power supply terminal
17	SDO	O	Dropout detection pulse output
18	VAD+	O	Power supply terminal for A/D converter (+)
19	VREF	O	Reference voltage output
20	VAD-	O	Power supply terminal for A/D converter (-)
21	OFTR	O	Off track detection ("H": det.)

Pin No.	Mark	I/O Division	Function
22	PLAY	I	Play signal ("H": ON, "L": OFF)
23	WVEL	I	Double velocity ("H": double, "L": single)
24	TES	I	Tracking error shunt ("H": shunt, "L": output)
25	PTO	O	Potential amp output
26	PTI	I	Potential amp input
27	PBO	O	Potential buffer output
28	POT	I	Potential buffer input
29	CROSS	O	Tracking error zero cross output
30	TE	O	Tracking error signal
31	TE BAL	I	Oscillation det. signal
32	TBAL	I	Tracking balance adj. input
33	VDET	O	Oscillation det. signal ("H": det.)
34	FE	O	Focusing error signal
35	FBL2	I	Focusing balance 2
36	FBL1	I	Focusing balance 1
37	Vcc	I	Power supply terminal
38	GND	—	GND terminal
39	PDBD	I	Photo detector Bch input with delay
40	PDA	I	Photo detector Ach input without delay
41	PDB	I	Photo detector Ach input with delay
42	PDAD	I	Photo detector Bch input without delay

• IC704 (MN6650) : Digital Servo Processor

Pin No.	Mark	I/O Division	Function
1	TES	O	Tracking error signal output
2	PLAY	O	play signal output
3	/RFDET	I	RF detection signal input
4	DO	I	Dropout signal input
5	OFT	I	Off track signal input
6	ARF	I	RF signal input
7	WVEL	O	High speed status signal output
8	PBO	I	Potension buffer signal input
9	TE	I	Tracking error signal input
10	FE	I	Focus error signal input
11	VR2	I	A/D reference voltage input
12	VR1	I	A/D reference voltage input
13	LDON	O	Laser power control signal output
14	VSS	—	Ground
15	AVSS	—	Ground
16	AVDD	I	Power supply (+5 V input)
17	VDD	I	Power supply (+5 V input)
18	TRV	O	Traverse servo control output
19	TVD	O	Traverse drive output
20	FOD	O	Focus drive output
21	TRD	O	Tracking drive output
22	KICK	O	Track kick signal output

• IC705 (MN6475) : Digital filter

Pin No.	Mark	I/O Division	Function
1	LRCK	I	Clock input
2	BCLK	I	Serial data clock input
3	SRDATA	I	Serial data input
4	COT1	—	Ground
5	COT2		
6	TEST		
7	VDD	I	Power supply (+5V input)
8	X2	—	Clock (f=33.8688 MHz)
9	X1		
10	VSS	—	Ground
11	AVDDL	I	Power supply (+5V input)
12	OUT.L	O	AF signal output (Lch)

Pin No.	Mark	I/O Division	Function
23	/TEST	I	+5 V input
24	VSS	—	Ground
25	CLVS	I	Spindle servo signal input
26	/TRON	O	Tracking servo signal output
27	MDATA	I	Command data input
28	MCLK	I	Command clock signal input
29	MLD	I	Command load signal input
30	SENSE	O	Sense signal output
31	/FLOCK	O	Focus servo signal output
32	/TLOCK	I	Tracking servo signal output
33	/RST	I	Reset signal input (L:Reset)
34	XI	I	Clock input (fXI= 16.9344MHz)
35	T0	—	Open
36	T1		
37	T2		
38	T3	—	Ground
39	T4		
40	T5		
41	T6		
42	VDET	I	Vibration detecting signal input
43	TBAL	O	Tracking balance adjustment output
44	TRCRS	I	Track cross signal input

Pin No.	Mark	I/O Division	Function
13	AVSS.L	—	Ground
14	AVSS.R	—	Ground
15	OUT.R	O	AF signal output (Rch)
16	AVDD.R	I	Power supply input
17	/RST	I	Reset signal input
18	PWM	—	—
19	TP	—	Ground
20	WVEL	I	High speed status signal input
21	DEMPH	I	De-emphasis signal input
22	CSEL	I	+5V input
23	192FS	—	—
24	768FS	O	Clock output (f=16.9344 MHz)

• IC706 (MN6626) : Digital signal processor

Pin No.	Mark	I/O Division	Function
1	AVSS	—	Ground
2	IREF	I	Reference current input
3	ARF	I	RF signal input
4	DRF	I	DSL bias input
5	DSLIF	O	DSL loop filter
6	PLLF	I	PLL loop filter
7	AVDD	I	Power supply (+5V input)
8	RSEL	I	+5V input
9	TBUS7	—	Test terminal (Ground)
16	TBUS0	—	
17	FLAG	—	
18	IPFLAG	—	
19	FCLK	—	
20	BYTCK	—	
21	WDCK	—	
22	/RST	I	Reset signal input
23	TX	O	Digital audio interface signal output
24	LDG	—	—
25	RDG	—	—
26	SRDATA	O	Serial data output
27	SCK	O	Serial bit clock output
28	LRCK	O	Clock output
29	XCK	O	Clock output (f=16.9344 MHz)
30	PMCK	—	—
31	CSEL	I	+5V input
32	PSEL	—	Ground
33	X1	I	Clock input (f=16.9344MHz)
34	X2	—	—
35	VSS	—	Ground

Pin No.	Mark	I/O Division	Function
36	SUBQ	O	Sub-code (Q data) output
37	SQCK	I	Sub-code (Q data) clock input f=7.3kHz
38	/CLDCK	—	—
39	BLKCK	O	Sub-code block (Q data) clock f=75Hz
40	DEMPH	O	De-emphasis ON signal output
41	MEMP	I	Emphasis signal input
42	MLD	I	Command load signal input
43	MCLK	I	Command clock signal input
44	MDATA	I	Command data input
45	DMUTE	I	Muting control signal input
46	SMCK	O	Clock output (f=4.2336MHz)
47	STAT	O	Status signal output
48	CRC	—	—
49	SUBC	—	—
50	SBCK	I	Clock for sub-code serial output
51	/TRON	I	Tracking servo ON signal input
52	CLVS	O	Spindle servo signal output
53	PC	—	—
54	ECM	O	Spindle motor control signal output
55	ECS	O	Spindle motor control signal output
56	VDD	I	Power supply (+5V input)
57	/TEST	I	+5V input
58	SSEL	I	+5V input
59	MSEL	—	—
60	RESY	—	—
61	DO	I	Drop out signal input
62	EFM	—	—
63	PCK	—	—
64	PDO	—	—

• IC901 (MND2410RLAB2) : Main microcomputer

Pin No.	Mark	I/O Division	Function
1	VDD	I	Power supply +5.6V
2	OSC1	I	Reference OSC terminal (connected to crystal oscillator 4 MHz)
3	OSC2	I	
4	VSS	—	GND
5	XI	I	Clock OSC terminal (connected to ceramic oscillator 32 kHz)
6	XO	O	—
7	VREF-	I	Reference voltage input
8	ADIN7	I	Deck 2 Forward Rec. Inh. switch select input terminal
9	ADIN6	I	Deck 2 cassette half detection signal input "HI" level in half detection switch in ON mode, "LOW" level in half detection switch in OFF mode.
10	ADIN5	I	Deck 1 cassette half detection signal input "HI" level in half detection switch in ON mode, "LOW" level in half detection switch in OFF mode.
11	ADIN4	—	Not used
12	ADIN3	I	Key control signal input (EDIT, TUNING, MODE, TITLE, DISPLAY, BAND)
13	ADIN2	I	Cassette operation control signal
14	ADIN1	I	CD operation control signal
15	ADIN0	I	Key control signal input (TIMER, SET, TAPE, SLEEP, CANCEL, TUNER)
16	VREF+	I	Reference voltage input (+5)
17	JOGA	I	JOG dial signal input
18	JOGB	I	JOG dial signal input
19	DC DET	—	Not used
20	PWM	—	Not used
21	MKDATA	—	Not used
22	MKCLK	—	Not used
23	ACLK	O	Audio control clock signal output
24	ADATA	O	Audio control data output
25	VOL B	I	Main volume control signal
26	PWRCNT	O	Output for voltage control signal
27	MUTE A	O	Output for muting control signal
28	VOL A	I	Main volume control signal
29	MBP1	—	Not used
30	MBP2	—	Not used
31	REMOCON IN	I	Remote control receiving signal
32	BLKCK	I	Sub-code block, clock signal (CD)
33	STATUS	I	CD start control signal input

• IC307 (BU2040F-E2) : I/O Expander

Pin No.	Mark	I/O Division	Function
1	GND	—	GND
2	DATA	I	Data input
3	CLK	I	Clock input
4	CD	O	CD drive signal output
5	TAPE	O	TAPE drive signal output
6	TUN	O	TUNER drive signal output
7	MUT. B	O	Mute control (bit 2) output
8	MO/ST	O	MONO/STEREO drive signal output

Pin No.	Mark	I/O Division	Function
9	VOL.MUT	O	Muting controls signal drive signal output
10	BASS	O	BASS drive signal output
11	AUX	O	AUX drive signal output
12	ALTS1	O	Attenuator control (bit 1)
13	ALTS2	O	Attenuator control (bit 2)
14	LO OPEN	O	Open loop control signal output
15	LO CLOSE	O	Close loop control signal output
16	VDD	I	+5V

■ INTERNAL CONNECTION OF FL (RSL5065-L)

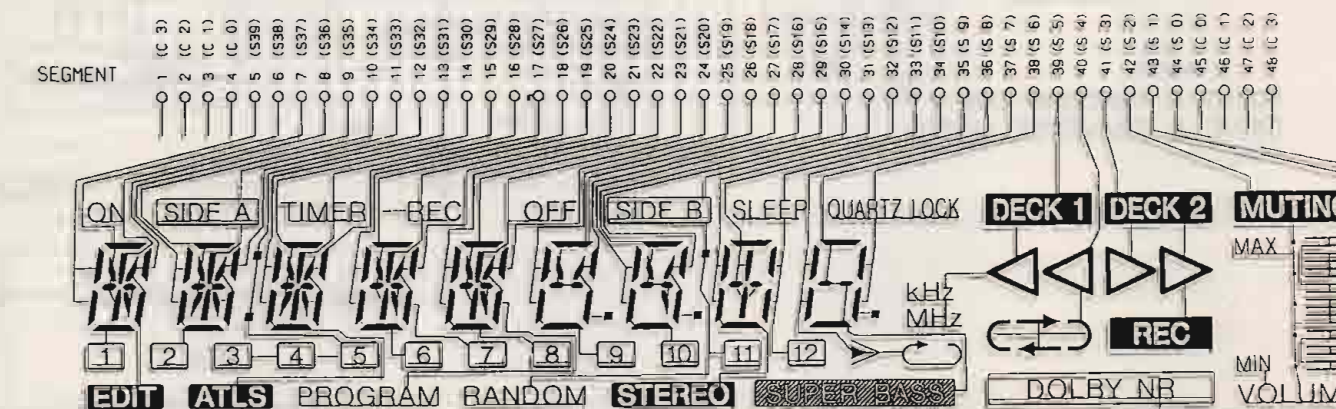
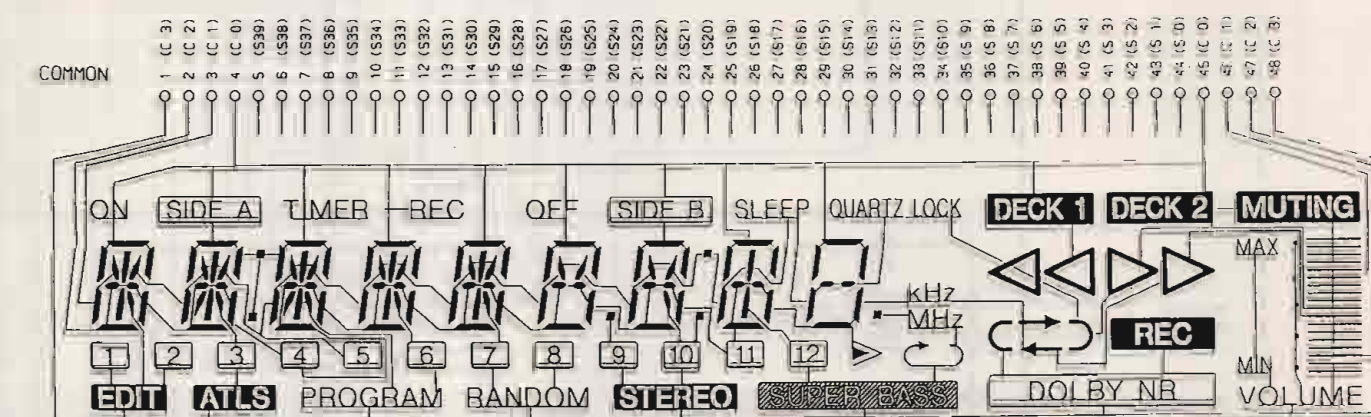

BLOCK DIAGRAM

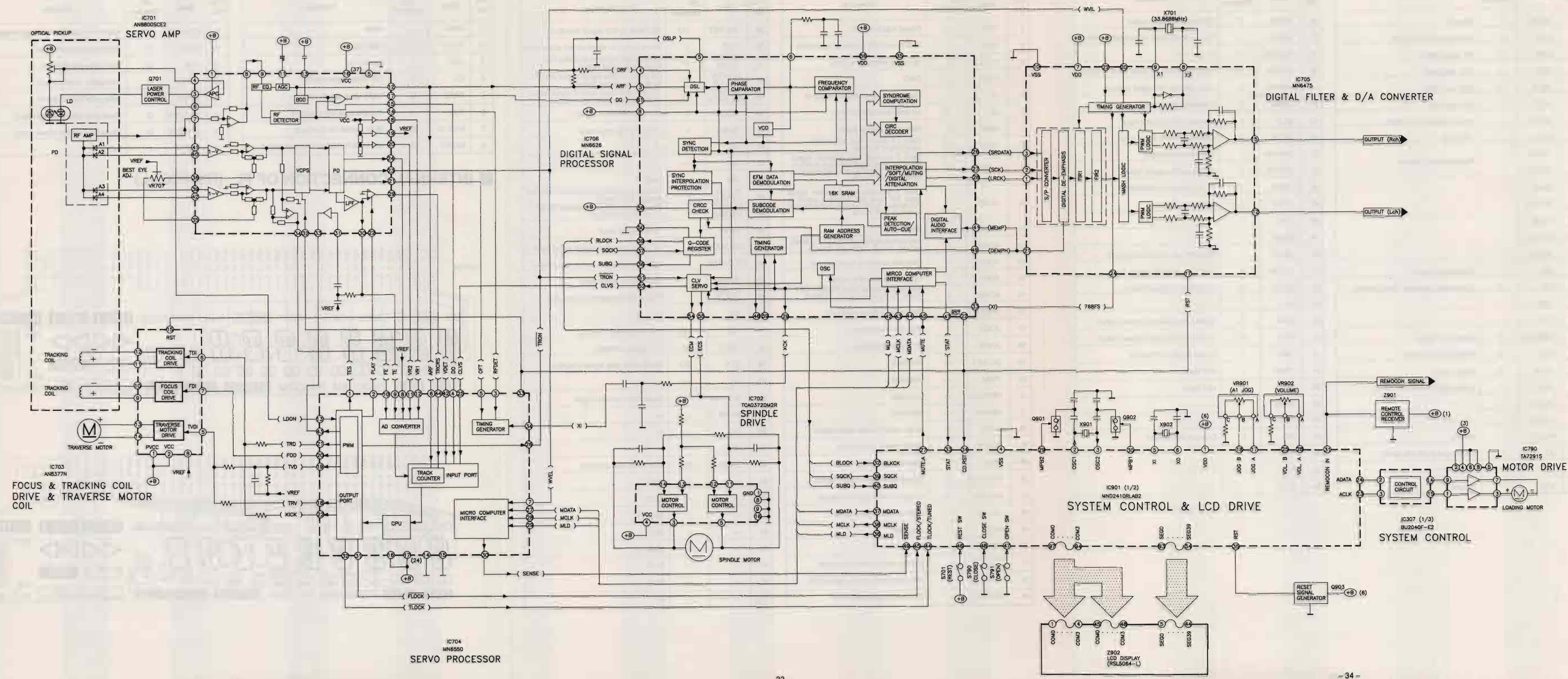

BLOCK DIAGRAM

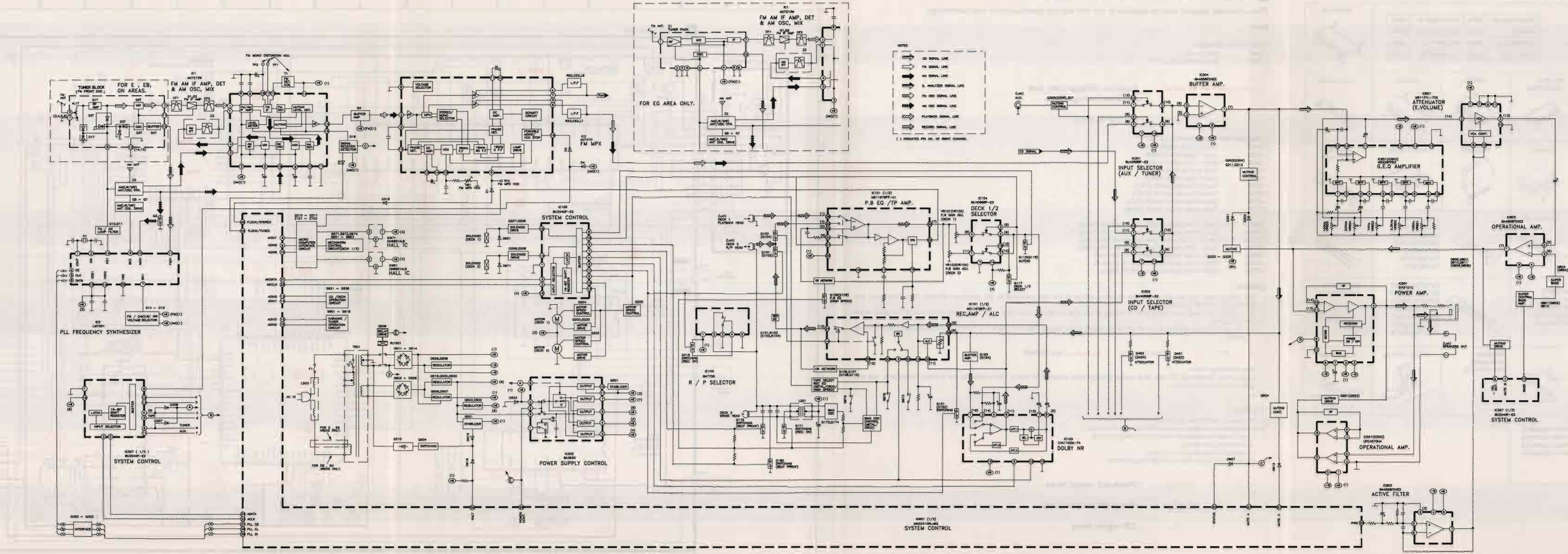

• TERMINAL GUIDE OF ICs, TRANSISTORS AND DIODES

BA4558FDXE2 	<table border="1"> <tr> <td>TCA0372DM2R</td> <td>16Pin</td> <td>CXA1102M-T4</td> <td>16Pin</td> </tr> <tr> <td>MN6475</td> <td>24Pin</td> <td>M51167BFP-E1</td> <td>36Pin</td> </tr> <tr> <td>AN8800SCE2</td> <td>42Pin</td> <td>M5226FPE2</td> <td>16Pin</td> </tr> <tr> <td>BU2040F-E2</td> <td>16Pin</td> <td>BU4066BF-E2</td> <td>14Pin</td> </tr> </table>			TCA0372DM2R	16Pin	CXA1102M-T4	16Pin	MN6475	24Pin	M51167BFP-E1	36Pin	AN8800SCE2	42Pin	M5226FPE2	16Pin	BU2040F-E2	16Pin	BU4066BF-E2	14Pin	AN7273W
TCA0372DM2R	16Pin	CXA1102M-T4	16Pin																	
MN6475	24Pin	M51167BFP-E1	36Pin																	
AN8800SCE2	42Pin	M5226FPE2	16Pin																	
BU2040F-E2	16Pin	BU4066BF-E2	14Pin																	
<table border="1"> <tr> <td>MN6650</td> <td>44Pin</td> </tr> <tr> <td>MN6626</td> <td>64Pin</td> </tr> <tr> <td>MND2410RLAB2</td> <td>100Pin</td> </tr> </table>	MN6650	44Pin	MN6626	64Pin	MND2410RLAB2	100Pin	TA7291S UPC4570HA 	LM7001 	AN7470 	DN6851ALB 										
MN6650	44Pin																			
MN6626	64Pin																			
MND2410RLAB2	100Pin																			
AN8377N 	BA3920 	BA7755 	SV3101C 	M51131L-702 	2SB1185E 2SD1782F 															
2SB709 	2SK301QTA 	2SK544F-AC 	2SB621RTA 2SD592RTA 2SD965RTA 2SC1675FL1LA 2SA564RTA 2SC2001KTA 2SA564QTA 	2SJ40CDTA 																
	BA1A4ZTA BN1A4MTA BA1L4MTA 2SC2785FTA 2SC2786MTA 2SA933SSTA	BA1A4MTA BN1L3NTA 2SC2784FTA 2SC2787LTA 2SD1450STA	RVDTA114EST RVDTA124EST RVDTA143XST RVDTA144TST 2SC1740SLNET 2SC1740SLMTA 2SC1740SQSTA	2SB1357ETA 2SD2037EFTA 																
RL154M11 1D3E 	MA110TW 	1SS291TA 1SR35200TB RVD1SS133TA 	SVC211SPA-AL 	SLR33VC160 																
	RVDMT24R7BTA RVDMT23R6BTA RVDMT28R2CTA RVDMT23R6BTA RVDMT28R2CTA RVDMT23R6BTA RVDMT28R2CTA	RVDMT28R2BTA RVDMT26R2BTA RVDMT28R8BTA RVDMT26R8BTA																		

■ SCHEMATIC DIAGRAM (Parts list on page 72 - 83)

(This schematic diagram may be modified at any time with the development of new technology)

Note :

- < for Servo circuit >
 • S701 : Reset switch.
 • VR701 : Best eye adjustment VR.

< for Mechanism control circuit >

- S951 : Deck 1 mode detect switch.
- S952 : Deck 1 tape detect switch.
- S953 : Deck 1 tape select switch.
- S971 : Deck 2 mode detect switch.
- S972 : Deck 2 tape detect switch.
- S973 : Deck 2 tape tab switch (REV).
- S974 : Deck 2 tape tab switch (FWD).
- S975 : Deck 2 tape select switch (CrO₂).
- S976 : Deck 2 tape select switch (Metal).

- VR101 : Deck 1 Lch playback gain adjustment VR (Dolby).
- VR102 : Deck 1 Rch playback gain adjustment VR (Dolby).
- VR103 : Deck 2 Lch playback gain adjustment VR (Dolby).
- VR104 : Deck 2 Rch playback gain adjustment VR (Dolby).
- VR201 : Deck 1 tape speed adjustment VR (Normal).
- VR202 : Deck 2 tape speed adjustment VR (Normal).
- VR203 : Deck 2 tape speed adjustment VR (High).

General

- The voltage value and waveforms are the reference voltage of this unit measured by DC electronic voltmeter (high impedance) and oscilloscope on the basis of chassis.
- Accordingly, there may arise some error in voltage values and waveforms depending upon the internal impedance of the tester or the measuring unit.
- * The parenthesized are the values of voltage generated during playing (Test disc 1 kHz, L + R, 0 dB), others are voltage values in stop mode.

()...CD << >>...Tape Recording No mark...Tape Playback

- Important safety notice: Components identified by Δ mark have special characteristics important for safety. When replacing any of these components, use only manufacture's specified parts.

Caution!

- IC, LSI are sensitive to static electricity. Secondary trouble can be prevented by taking care during repair.
- Cover the parts boxes made of plastics with aluminum foil.
- Ground the soldering iron.
- Put a conductive mat on the work table.
- Do not touch the pins of IC or LSI with fingers directly.

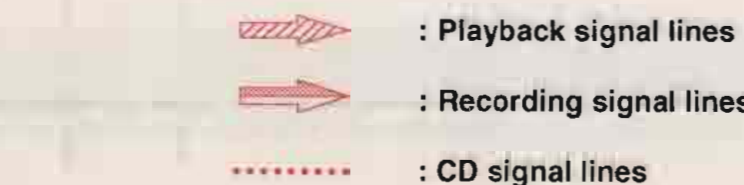

■ SCHEMATIC DIAGRAM

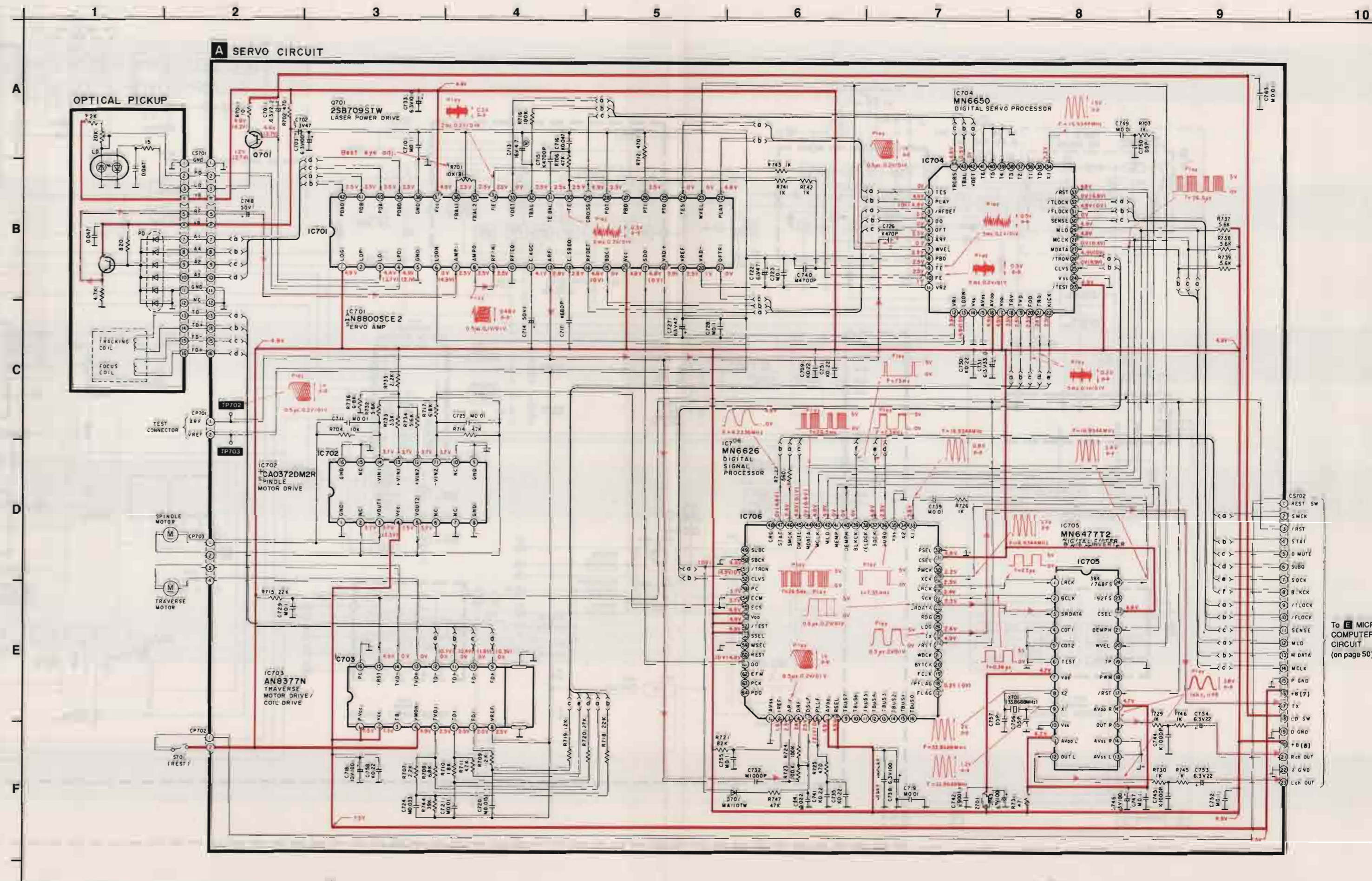

To MICRO COMPUTER CIRCUIT (on page 50)

SCHEMATIC DIAGRAM (Tape Deck)

1 2 3 4 5 6 7 8 9 10 11 12 13 14

B MECHANISM CONTROL CIRCUIT

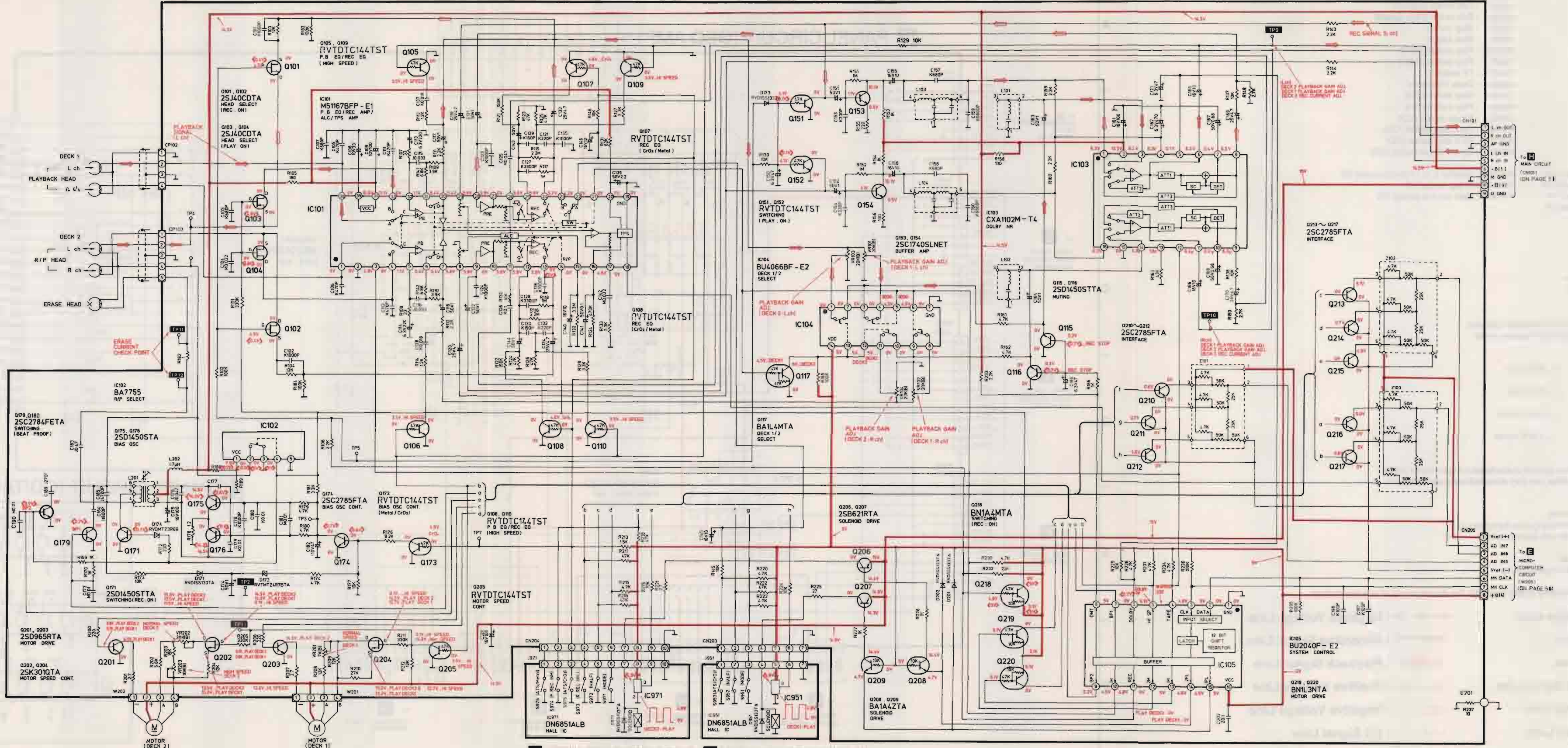

C MECHANISM (DECK2) CIRCUIT D MECHANISM (DECK1) CIRCUIT

Note :

< for panel circuit >

- S601 : Tuner switch
- S602 : CD switch
- S603 : Aux. switch
- S604 : Tape switch
- S605 : Super bass switch
- S606 : Power on/off switch
- S607 : Play timer switch
- S608 : Record timer switch
- S609 : Volume preset switch
- S610 : Set switch
- S611 : Cancel switch
- S612 : FM mode switch
- S613 : Band switch
- S614 : Tuning switch
- S615 : CD edit switch
- S616 : Display switch
- S617 : Clock / Timer switch
- S618 : Sleep switch
- S621 : REV mode switch
- S622 : Reset switch
- S623 : Dolby switch
- S624 : Record switch
- S625 : Edit switch (Normal)
- S626 : Edit switch (High Speed)
- S627 : Stop switch
- S628 : Rew switch
- S629 : Play switch (REV)
- S630 : Play switch (FWD)
- S631 : FF switch
- S632 : Deck 1/2 switch
- S633 : Stop switch (CD)
- S634 : Play switch (CD)
- S635 : Pause switch (CD)
- S636 : FWD skip switch (CD)
- S637 : REV skip switch (CD)
- S638 : Open / Close switch (CD)

- VR651 : Graphic E.Q. (10kHz) control VR
- VR652 : Graphic E.Q. (3.3kHz) control VR
- VR653 : Graphic E.Q. (1kHz) control VR
- VR654 : Graphic E.Q. (330Hz) control VR
- VR655 : Graphic E.Q. (100Hz) control VR
- VR901 : AJ jog control VR
- VR902 : Main volume control VR

< for tuner circuit >

- VR1 : VCO adjustment VR

< for main circuit >

- S790 : Disk tray close detect switch
- S791 : Disk tray open detect switch

General

- DC voltages measurement are taken with electronic voltmeter.
- The negative terminal of the battery provides negative meter connection point.

- No mark...Tape Playback
- < >...FM mode
- ()...AM mode
- ()...CD mode
- ()...Tuner mode
- ()...Other mode
- ()...Aux. mode
- ()...TAPE mode

Important safety notice:

- Components identified by Δ mark have special characteristics important for safety.
- When replacing any of these components, use only manufacturer's specified parts.

Caution!

- IC and LSI are sensitive to static electricity.
- Secondary trouble can be prevented by taking care during repair.
- *Cover the parts boxes made of plastics with aluminum foil.
- *Ground the soldering iron.
- *Put a conductive mat on the work table.
- *Do not touch the pins of IC or LSI with fingers directly.

This schematic diagram may be modified at any time with the development of new technology.

- : Positive Voltage Line
- - - : Negative Voltage Line
- : FM Signal Line
- : Recording Signal Line
- : AM Signal Line
- : Playback Signal Line
- : AF (FM / AM) Signal Line
- - - : Positive Voltage Line
- : AM Osc Signal Line
- - - : Negative Voltage Line
- : FM Osc Signal Line
- : CD Signal Line

SCHEMATIC DIAGRAM

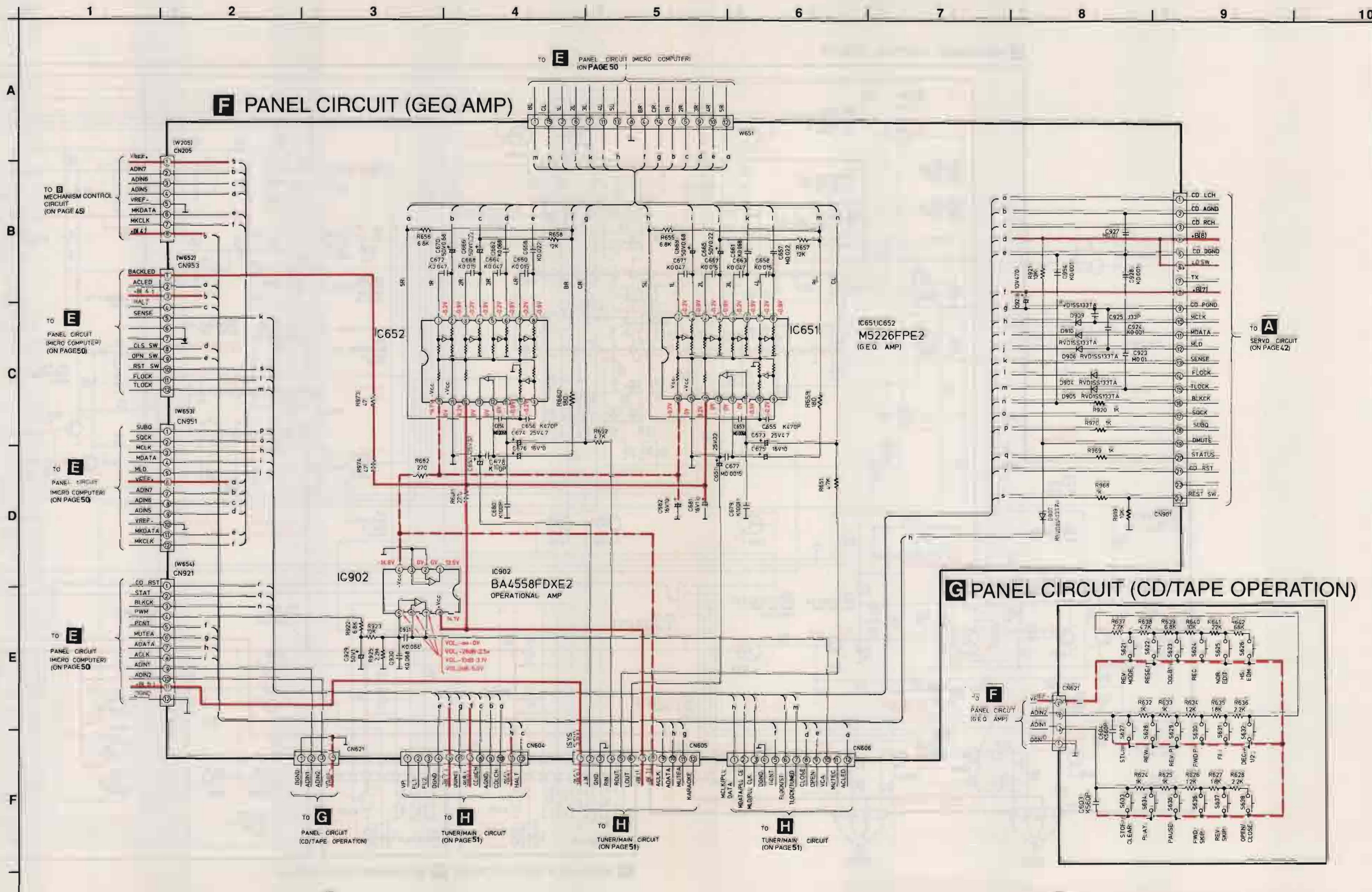

SCHEMATIC DIAGRAM

1 2 3 4 5 6 7 8 9 10

PANEL CIRCUIT (MICRO COMPUTER)

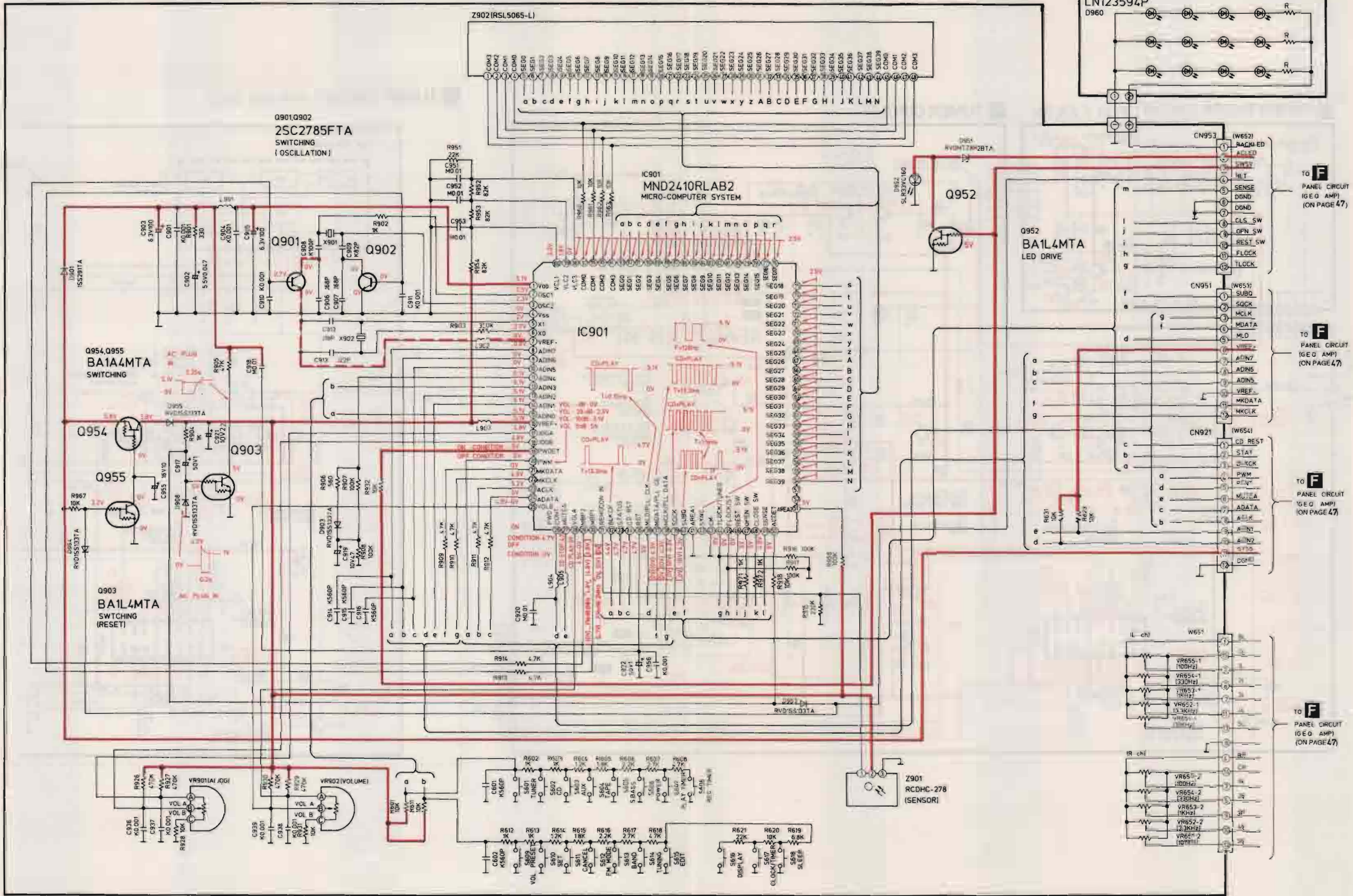

SCHEMATIC DIAGRAM

1 2 3 4 5 6 7 8 9 10

A
B
C
D
E
F

M TUNER BLOCK CIRCUIT FOR E, EB, GN

H TUNER CIRCUIT

H TUNER CIRCUIT FOR EG ONLY

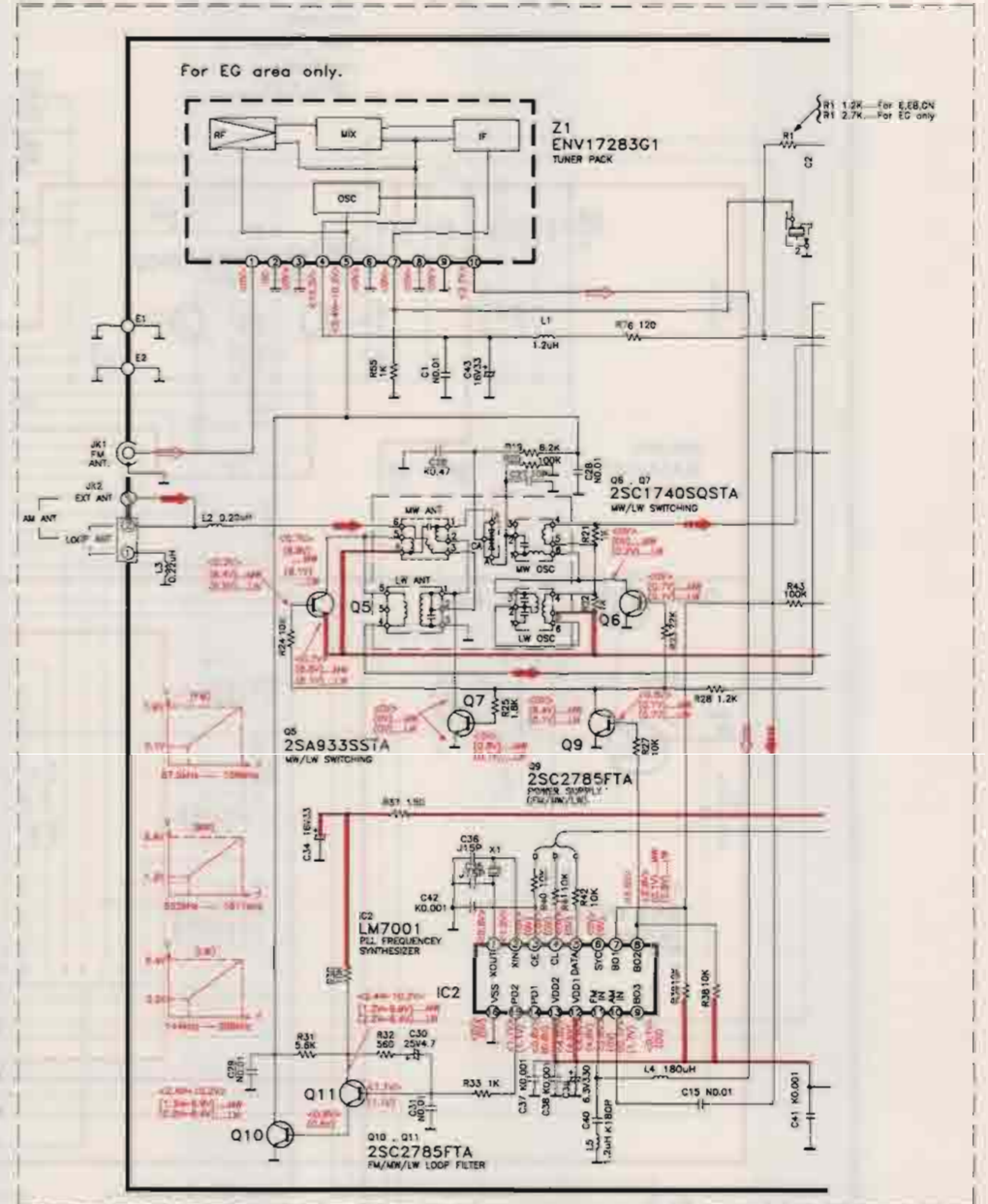
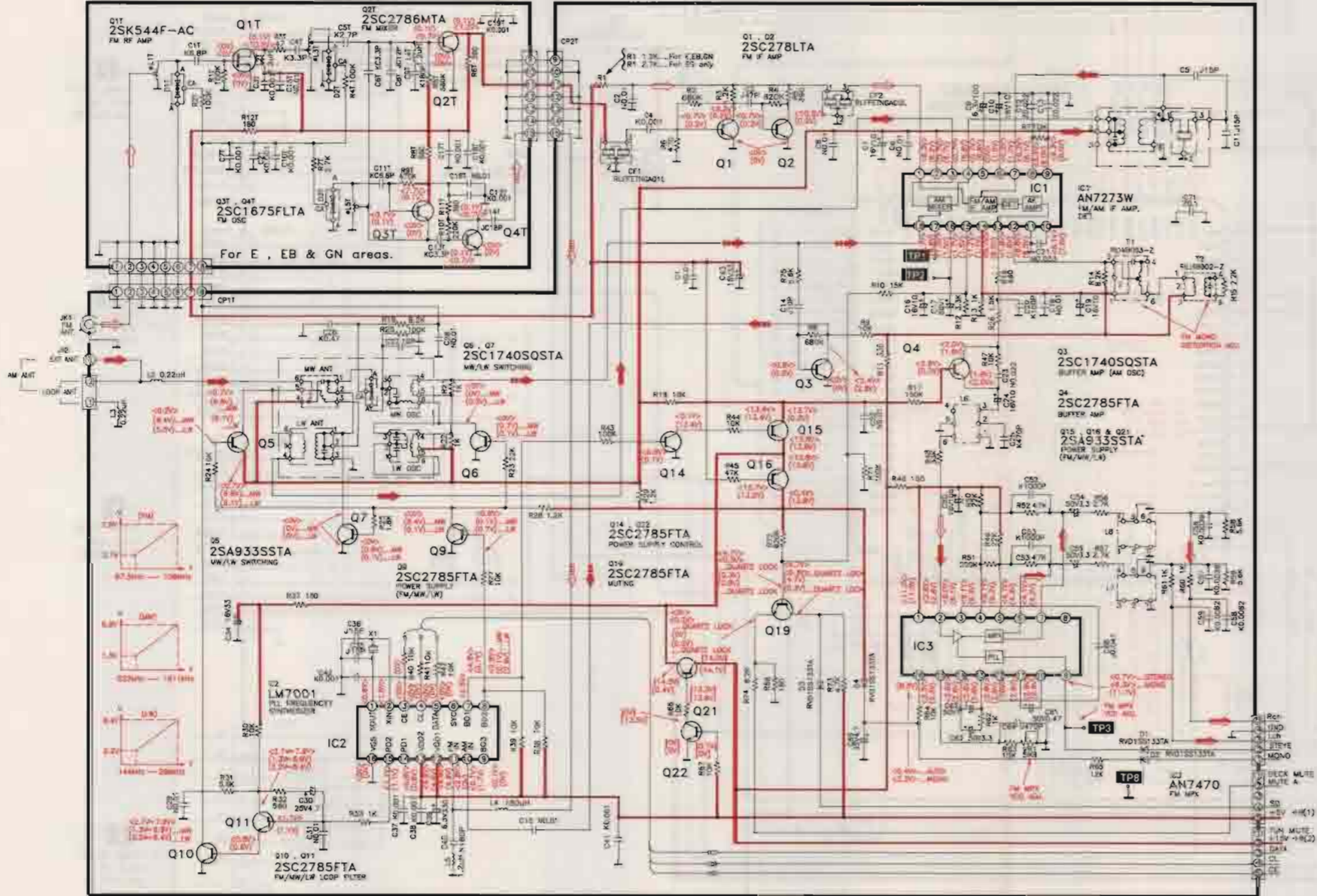

SCHEMATIC DIAGRAM

SA-CH11

SA-CH11

SA-CH11

SA-CH11

1 2 3 4 5 6 7 8 9 10 11 12 13 14 15 16 17 18 19

H MAIN CIRCUIT

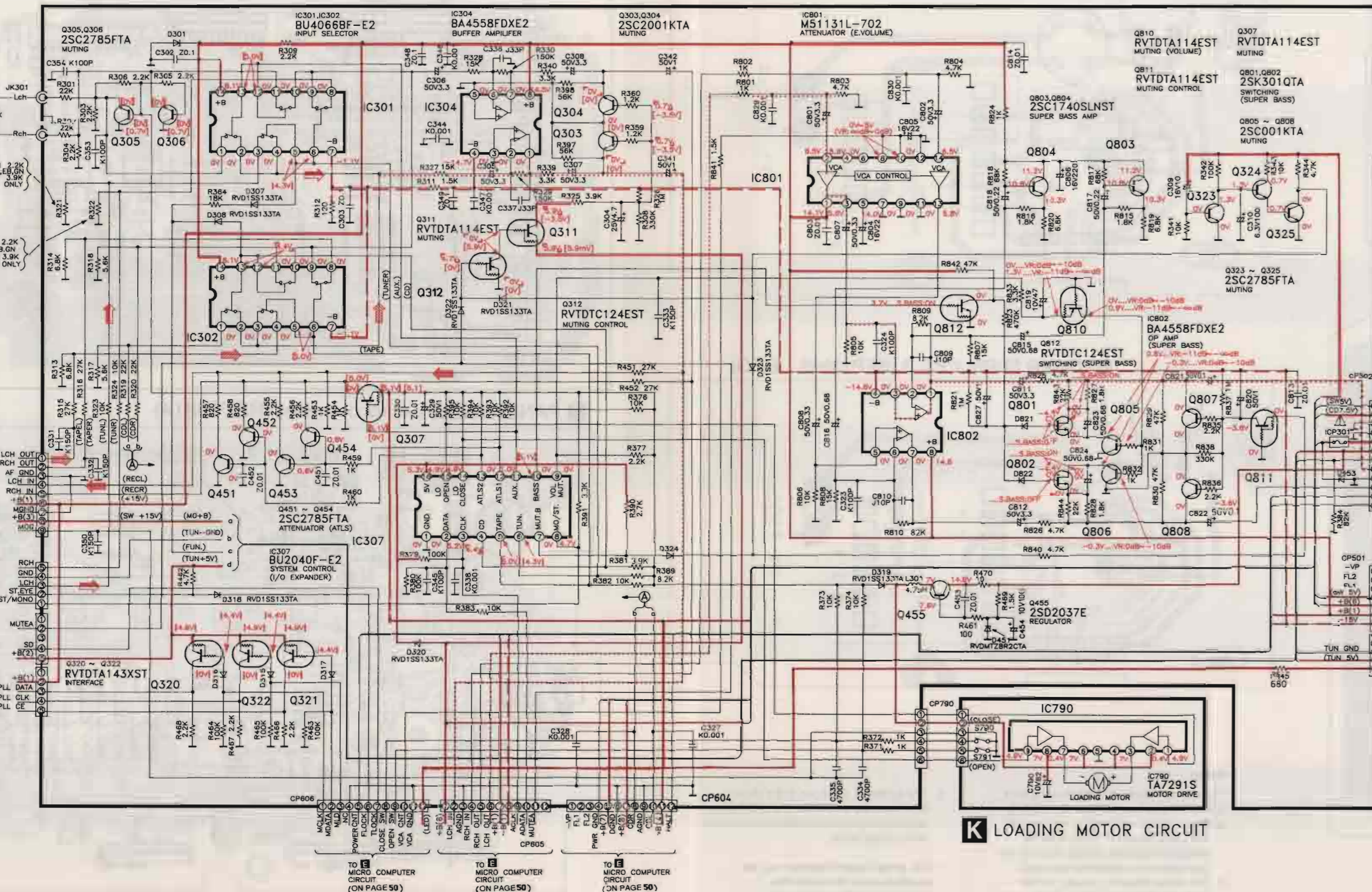

I POWER AMP. CIRCUIT

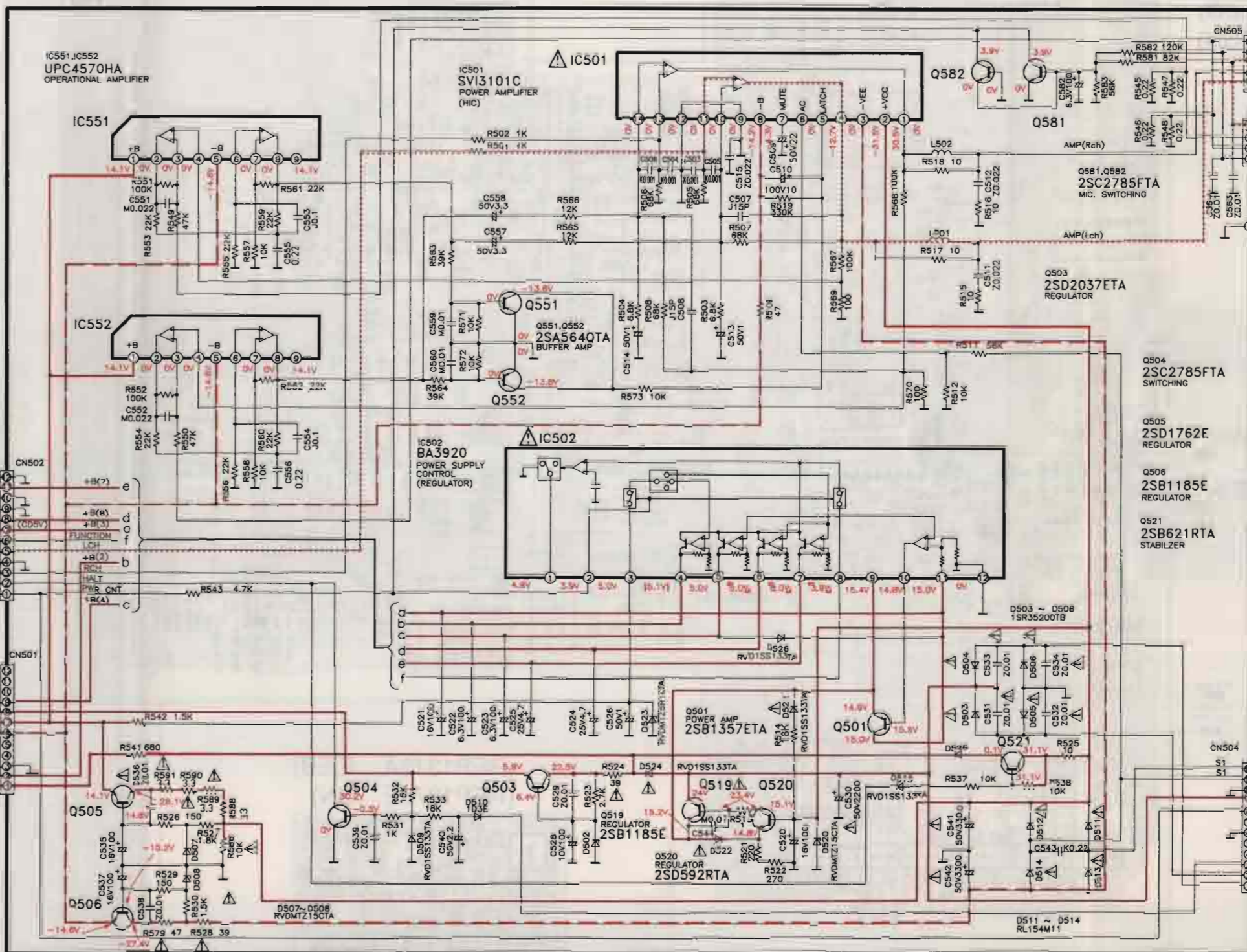

L HEADPHONE/SPEAKER CIRCUIT

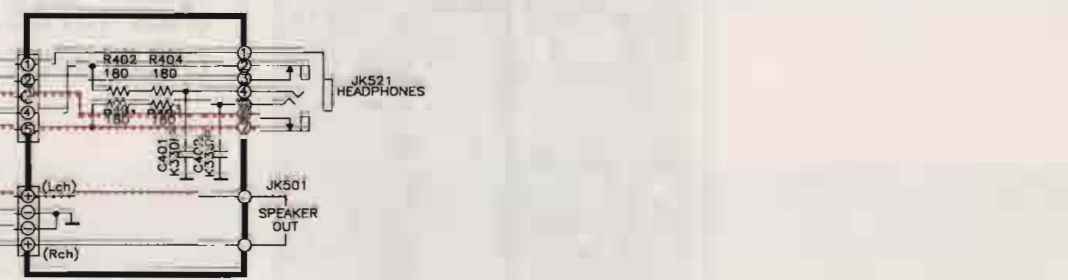

J POWER SUPPLY CIRCUIT FOR EB AND GN AREAS.

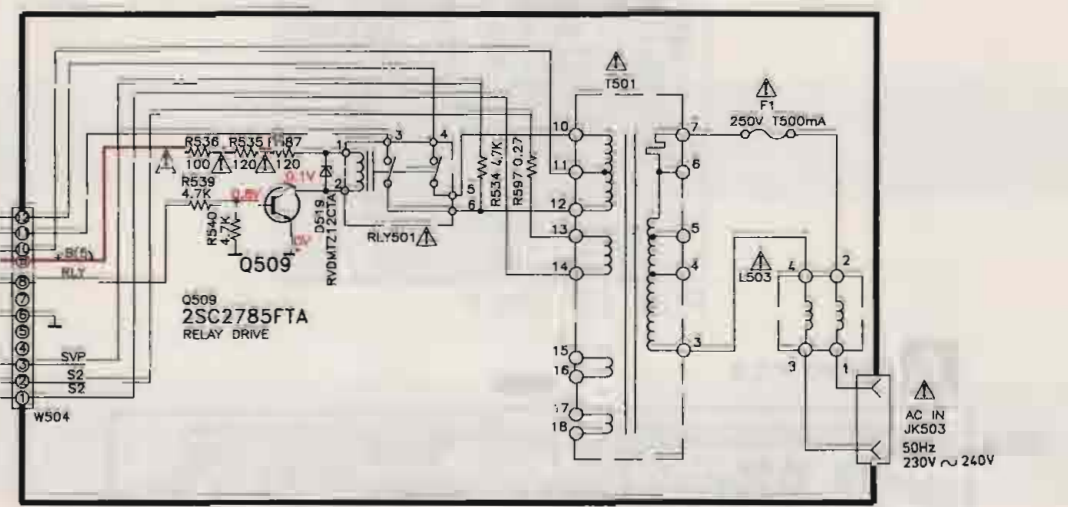

J POWER SUPPLY CIRCUIT FOR E AND EG AREAS.

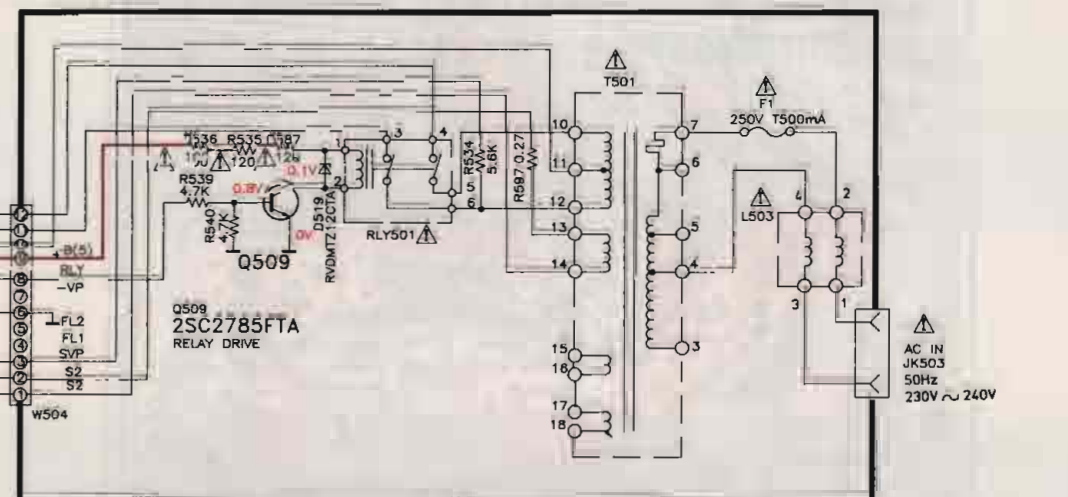

K LOADING MOTOR CIRCUIT

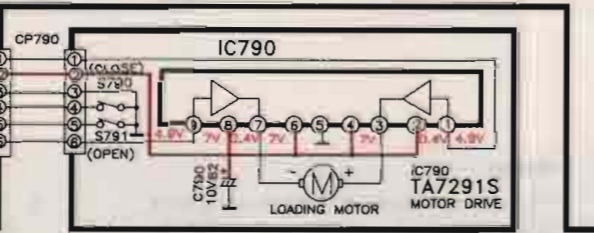

PRINTED CIRCUIT BOARDS

1 2 3 4 5 6 7 8 9 10 11 12 13 14 15 16 17 18 19

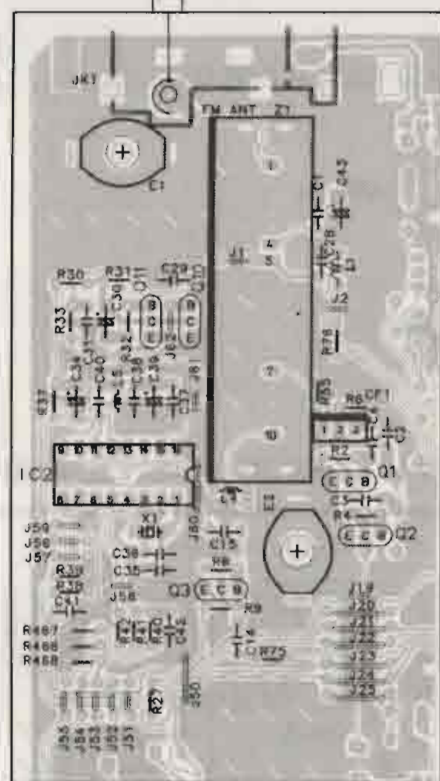

E MAIN/TUNER P.C.B. (REP1378A....E,EB) (REP1378B....EG) (REP1378E....GN)

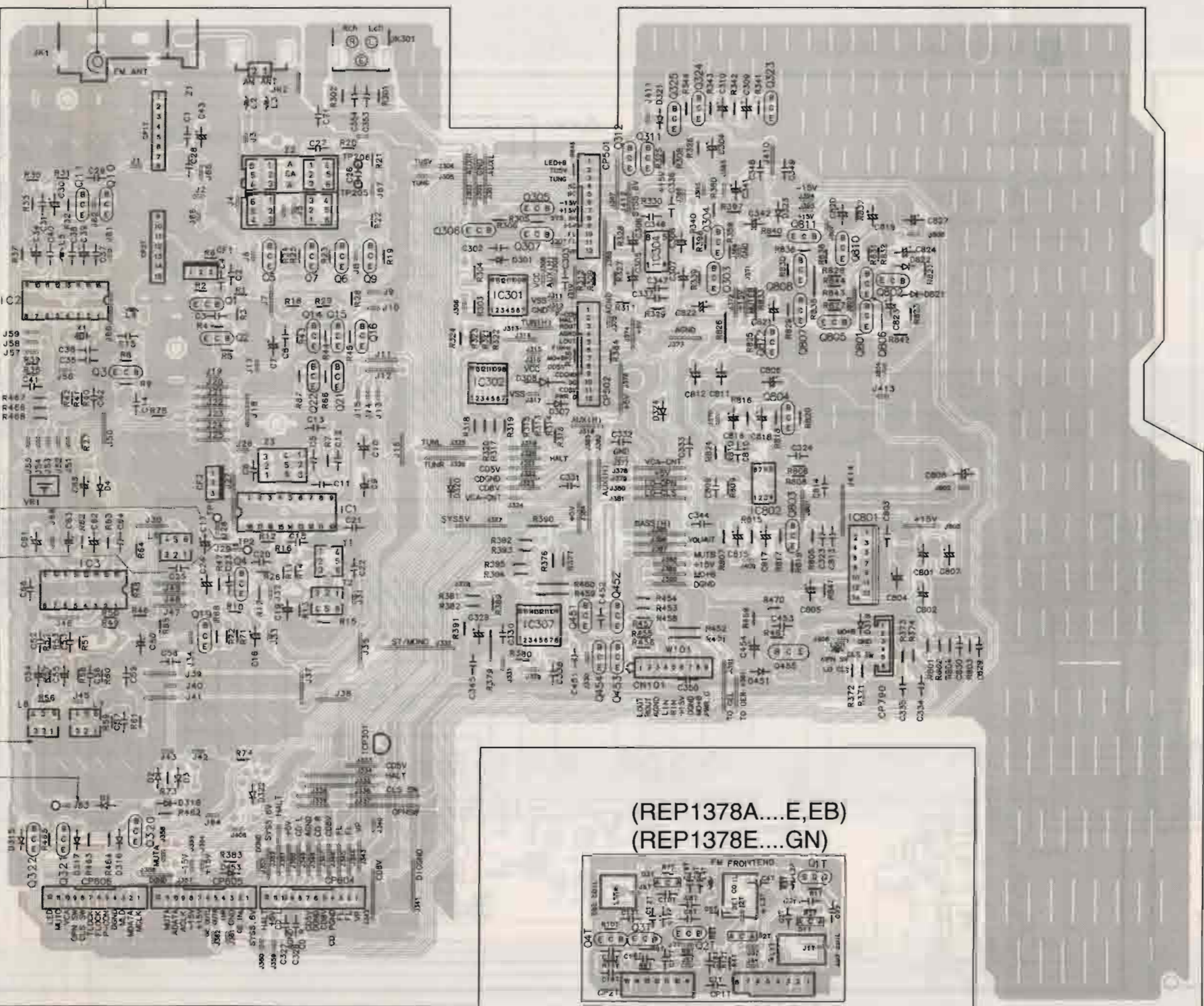

(REP1378A....E,EB) (REP1378E....GN)

M TUNER BLOCK P.C.B.

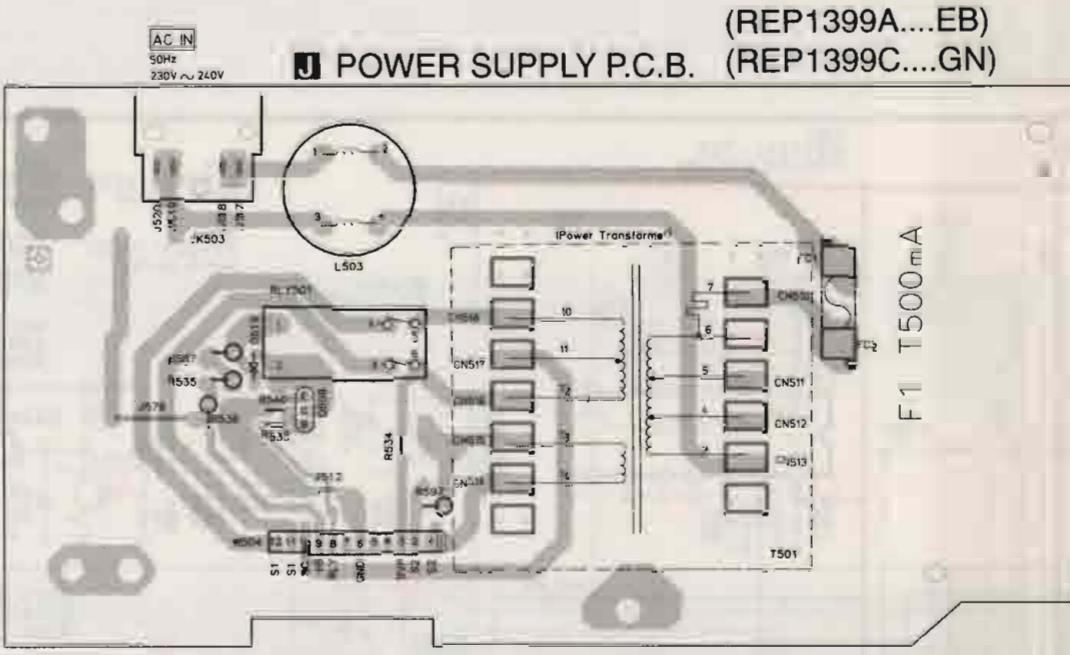

J POWER SUPPLY P.C.B. (REP1399A....EB) (REP1399C....GN)

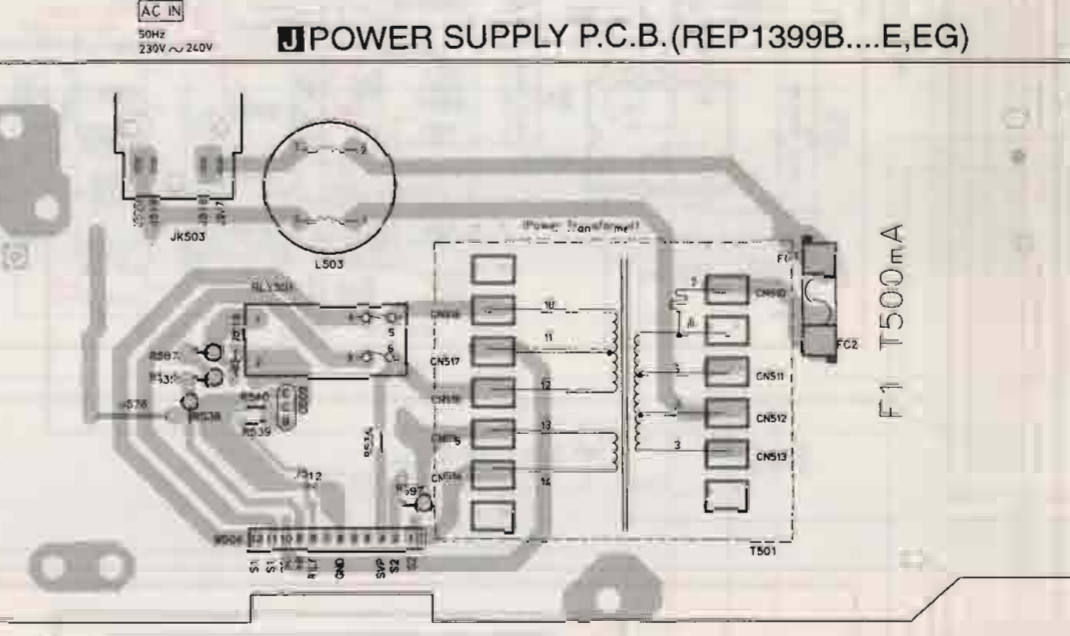

K POWER SUPPLY P.C.B. (REP1399B....E,EG)

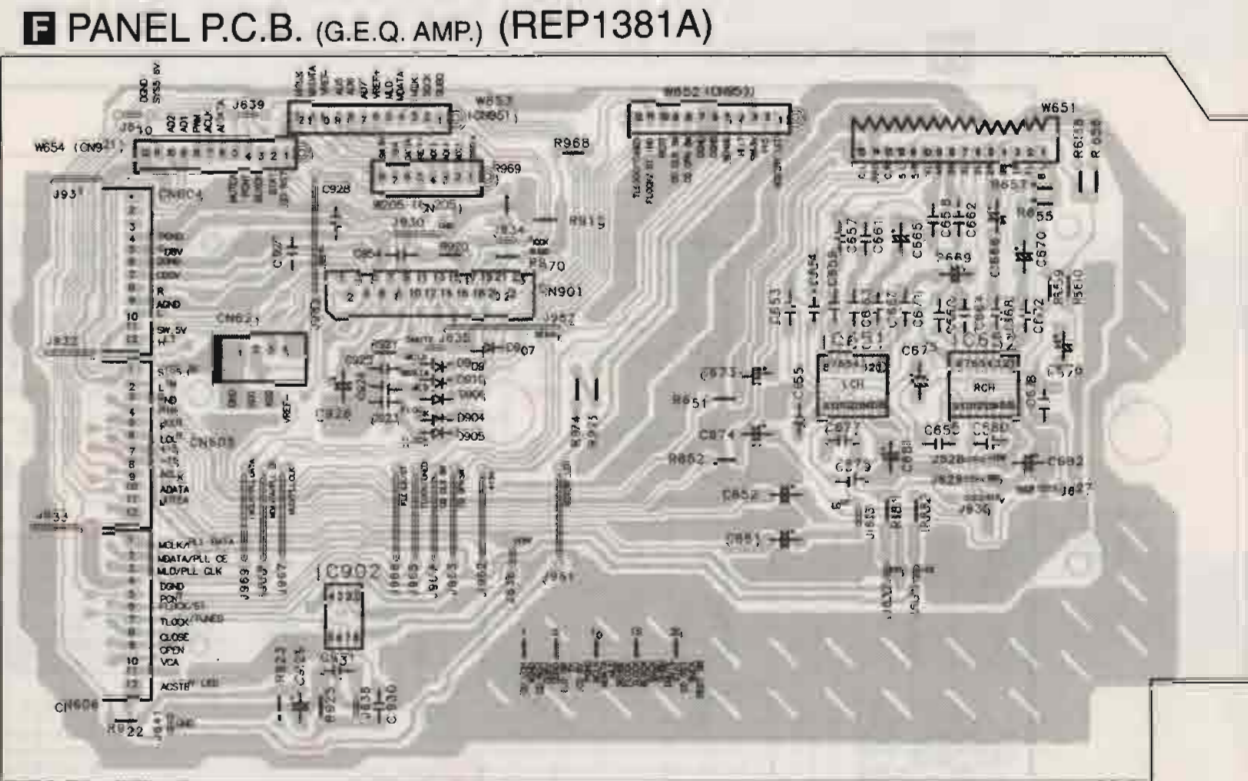

F PANEL P.C.B. (G.E.Q. AMP.) (REP1381A)

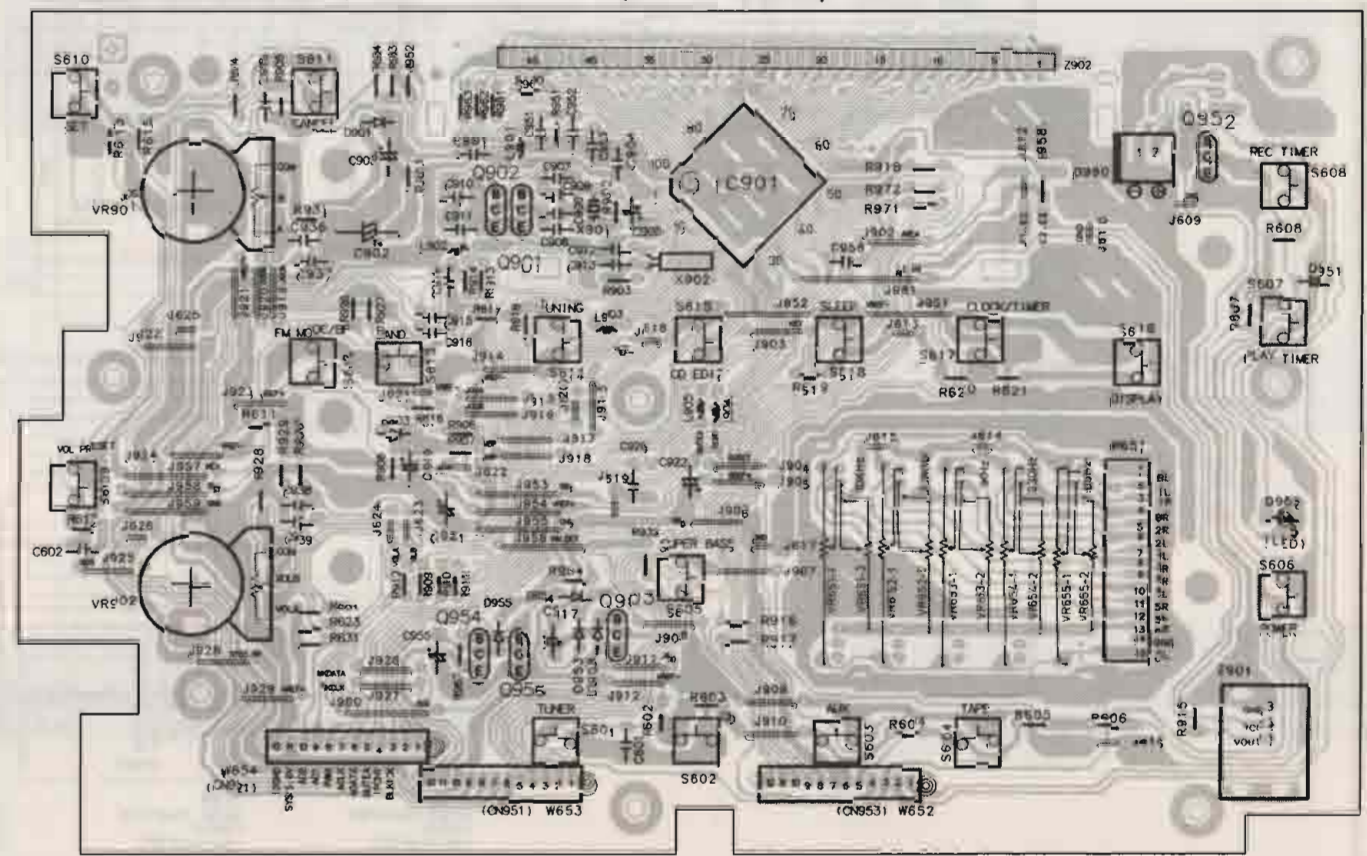

L PANEL P.C.B. (MICROCOMPUTER) (REP1381A)

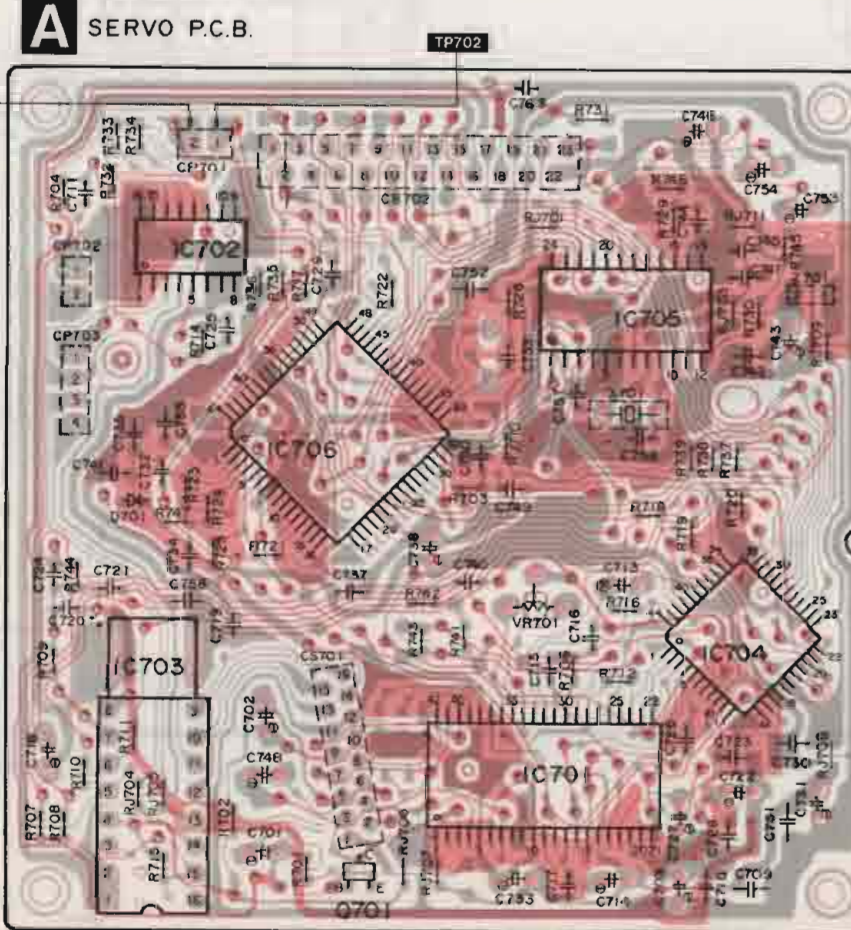

A SERVO P.C.B. (REP1370A....E,EB) (REP1370B....EG) (REP1370E....GN)

Notes:

- This diagram (Servo P.C.B.) shows a front view of the small outline type IC mounting surface.
- The circuit shown in () on the conductor indicates printed circuit on the back side of the printed circuit board.
- The circuit shown in () on the conductor indicates printed circuit on the front side of the printed circuit board.
- The symbols (•) shown in the circuit board indicate connection points between conductors on the front side and back side of the circuit board.
- This circuit board diagram may be modified at any time with the development of new technology.

PRINTED CIRCUIT BOARD

1 2 3 4 5 6 7 8 9 10

A

B

C

D

E

F

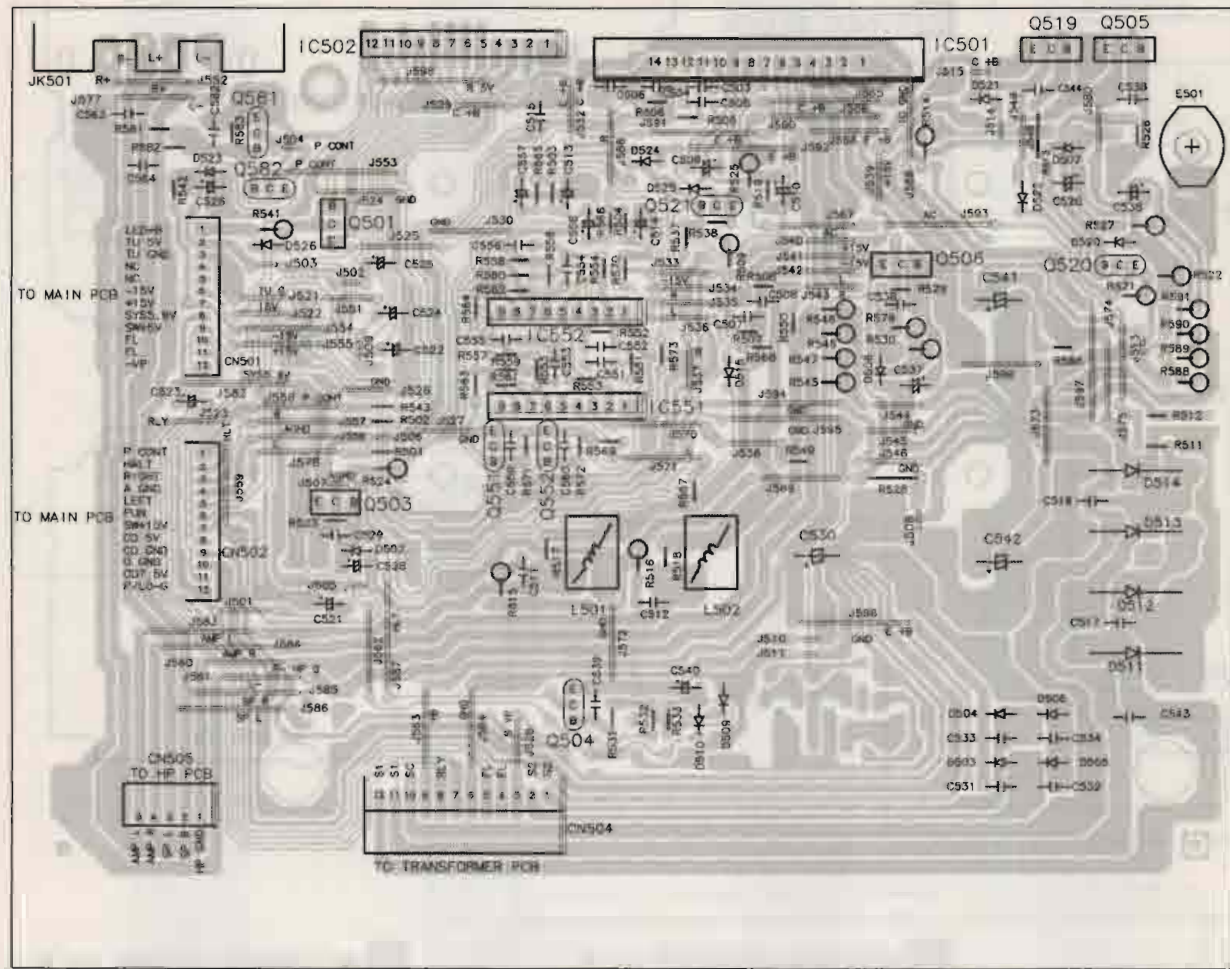

I POWER AMP. P.C.B.
 (REP1399A....EB)
 (REP1399B....E,EG)
 (REP1399C....GN)

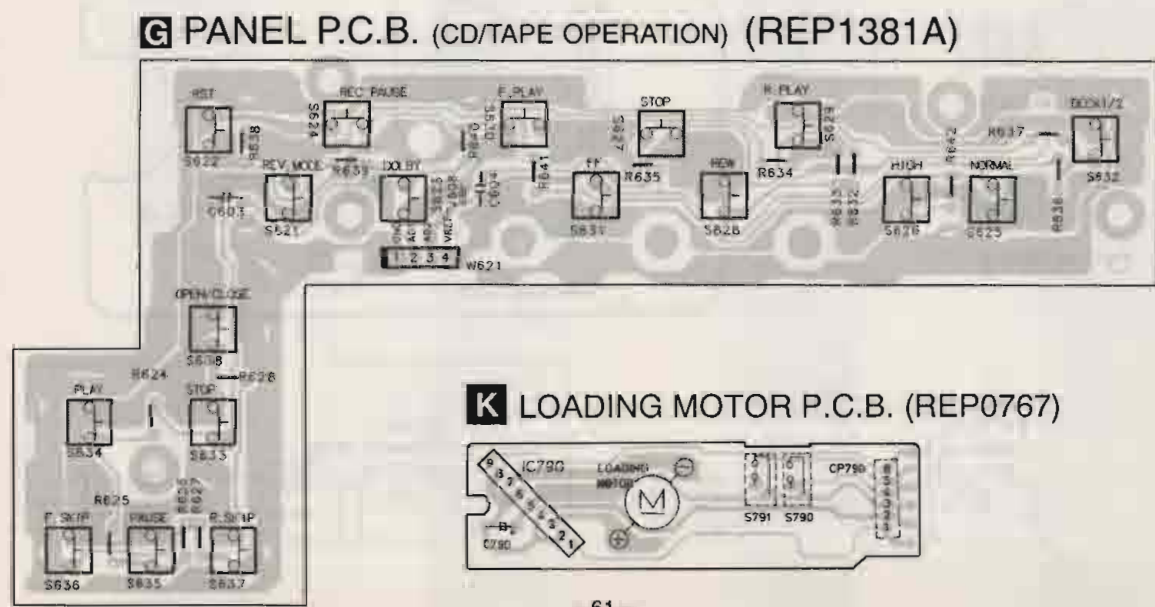

K LOADING MOTOR P.C.B. (REP0767)

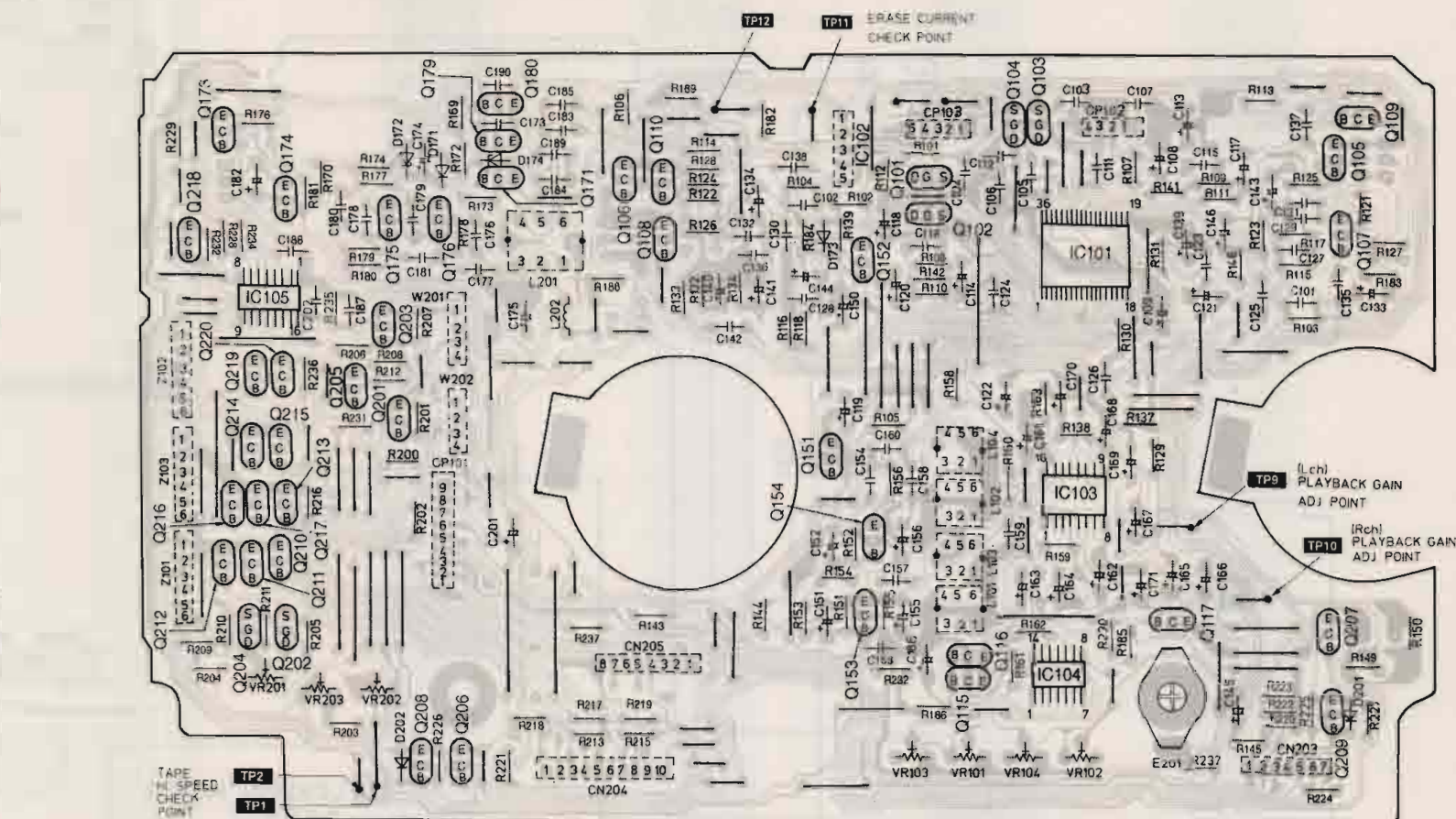

B MECHANISM CONTROL P.C.B (REP1379A)

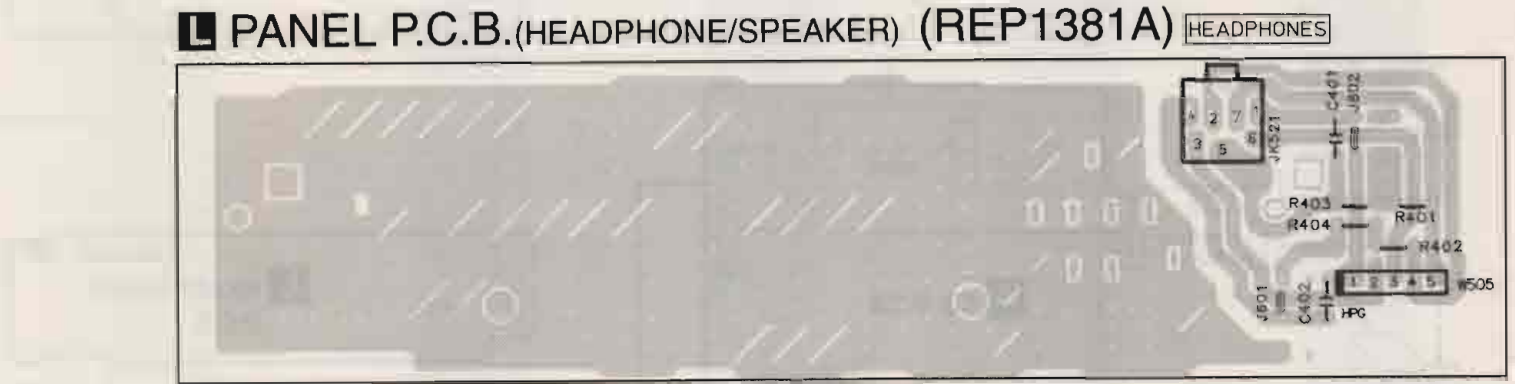

L PANEL P.C.B.(HEADPHONE/SPEAKER) (REP1381A) HEADPHONES

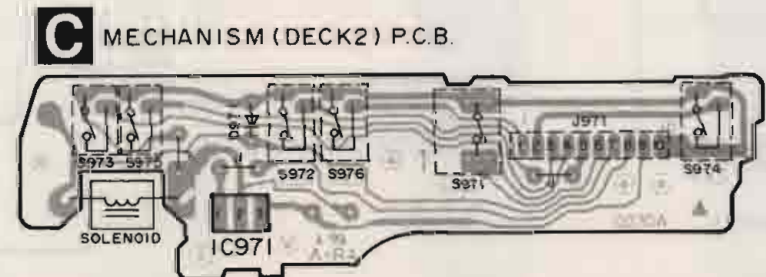

C MECHANISM (DECK2) P.C.B.

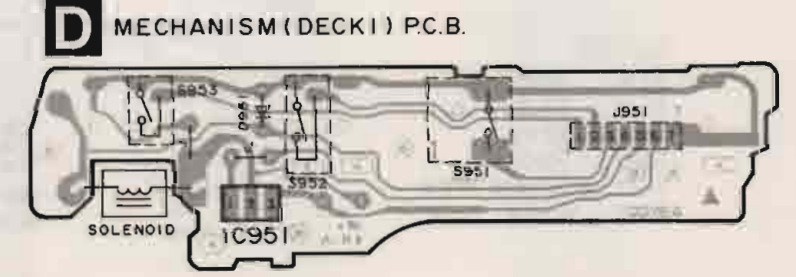

D MECHANISM (DECK1) P.C.B.

WIRING CONNECTION DIAGRAM

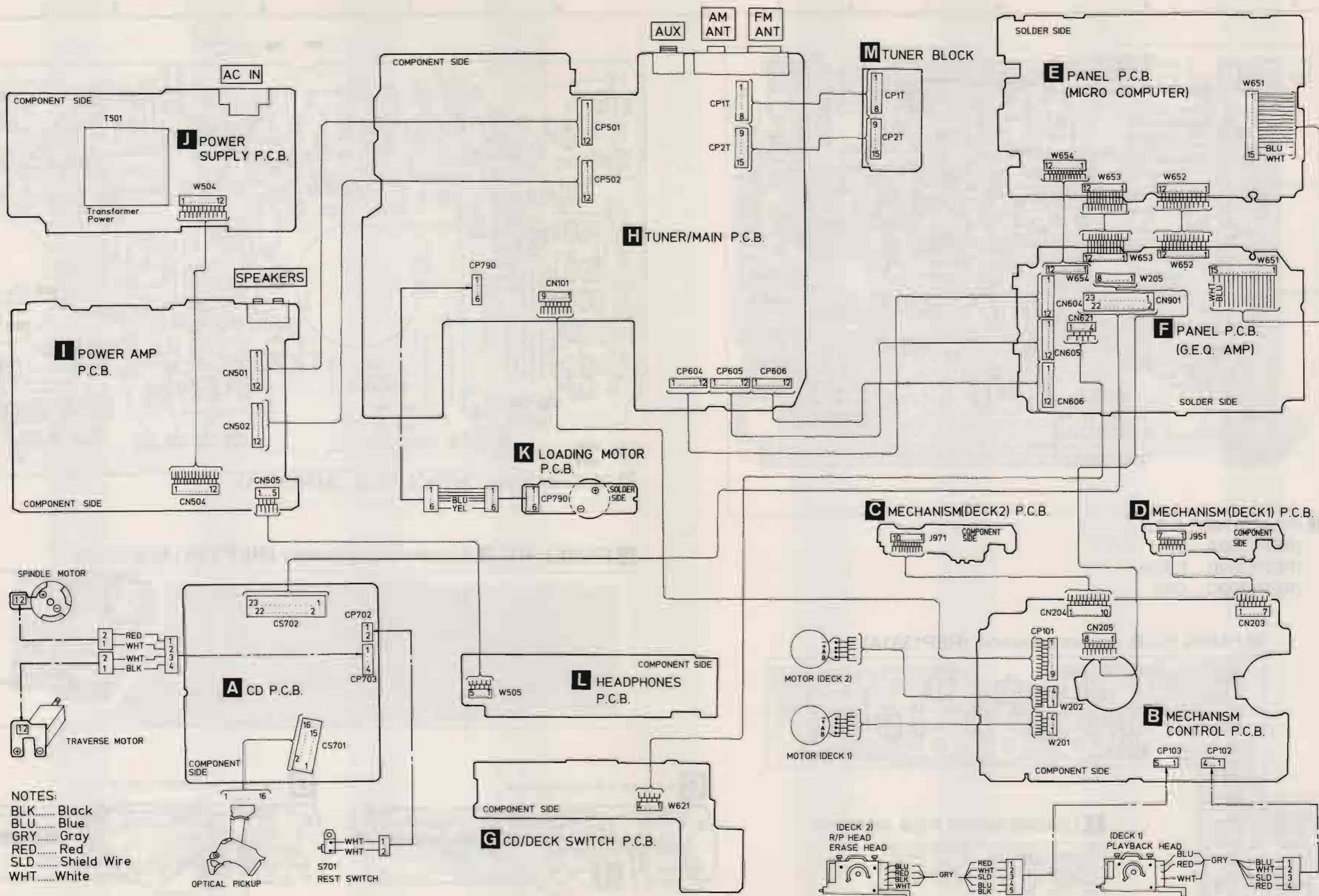

DIGITAL SERVO SYSTEM

The newly-developed digital servo system is adopted in the servo circuit of the unit's CD player instead of the ordinary analog servo system.

- The diagrams shown below represent differences between the analog servo and digital servo systems. The HEAD AMP. output signals (i.e., focus error and tracking error output signals) are analog. These analog signals are converted to the 8-bits digital signals through the MN6650. The MN6650 performs the following adjustments automatically; focus offset, tracking offset, focus gain, tracking gain and tracking balance adjustments. The outputs from the MN6650 such as the focus coil driving signal, tracking coil driving signal, and traverse motor driving signal are converted to analog signals again and sent to the coils and motor to perform proper servo control for a disc.

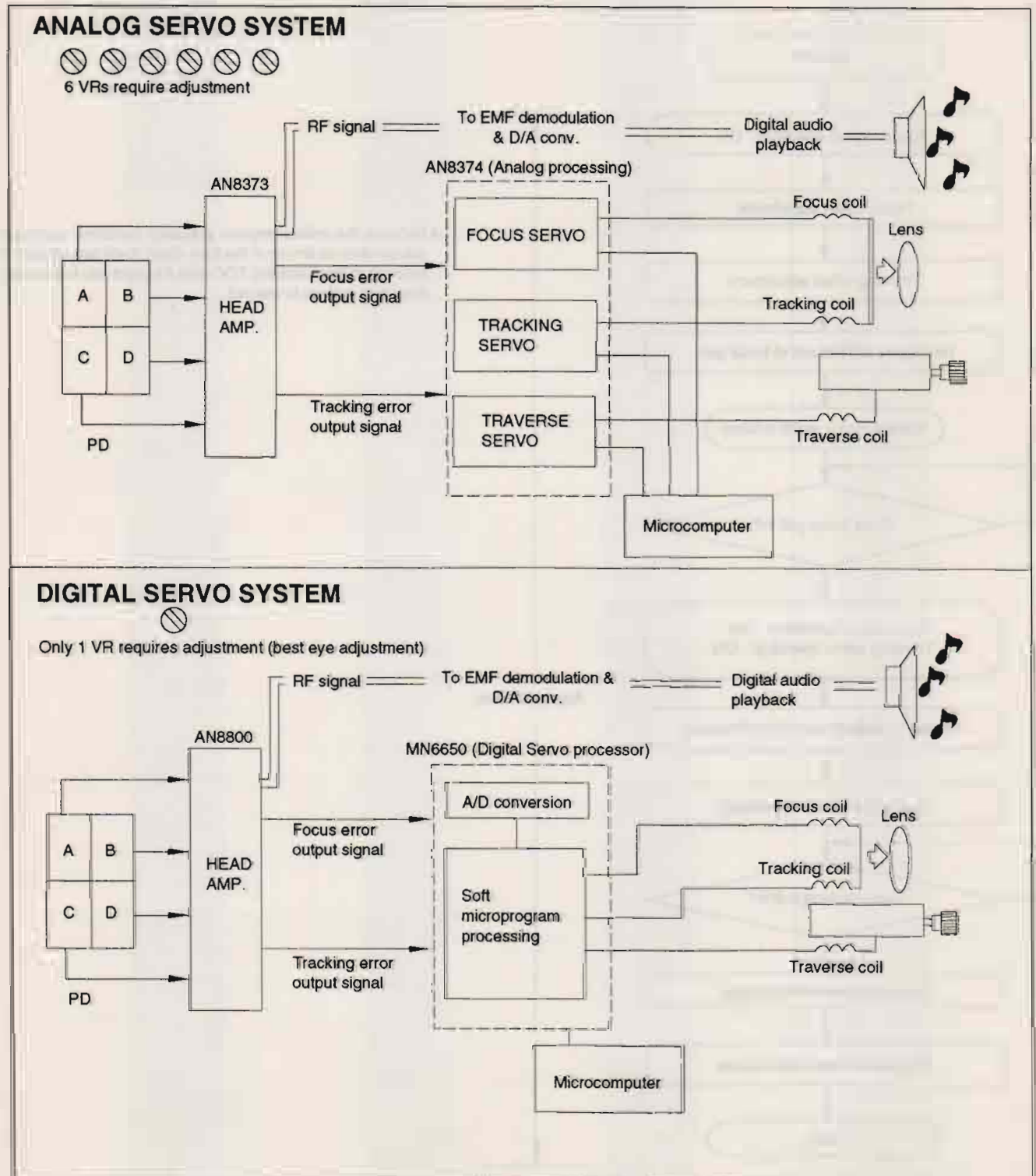

2. The servo processor IC MN6650 of the newly-developed digital servo circuit automatically performs the following adjustments which were originally adjusted in the conventional analog servo circuit:
 (1) Focus offset, (2) Tracking offset, (3) Focus gain, (4) Tracking gain, and (5) Tracking balance. Therefore, you do not have to perform the above-mentioned electrical adjustments manually. Only the best eye (PD balance) needs to be adjusted. You can obtain an optimum servo control for a disc to play.
 [You must perform the best eye (PD balance) adjustment manually.]

The following flow chart shows the sequence of automatic adjustments.

• Flow chart on automatic adjustment sequence

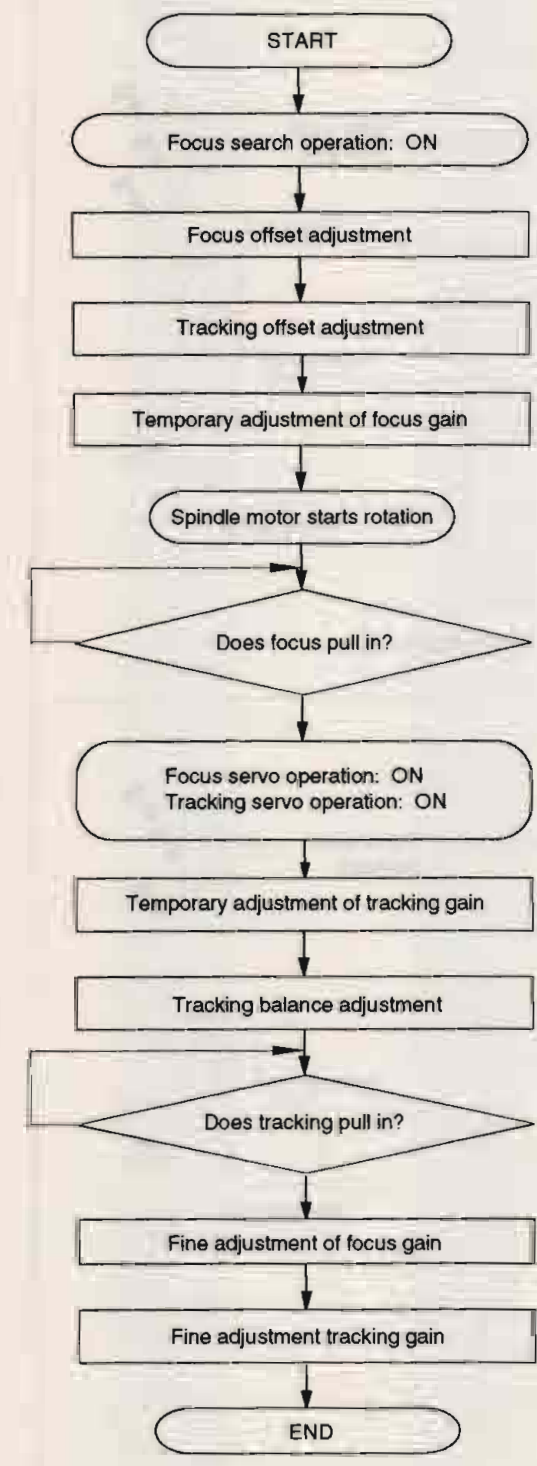

• Because the microcomputer precisely performs automatic adjustments as shown in the flow chart, it will take approx. 5 seconds to finish reading TOC data if a used disc is eccentric one or its surface is warped.

■ TROUBLESHOOTING GUIDE

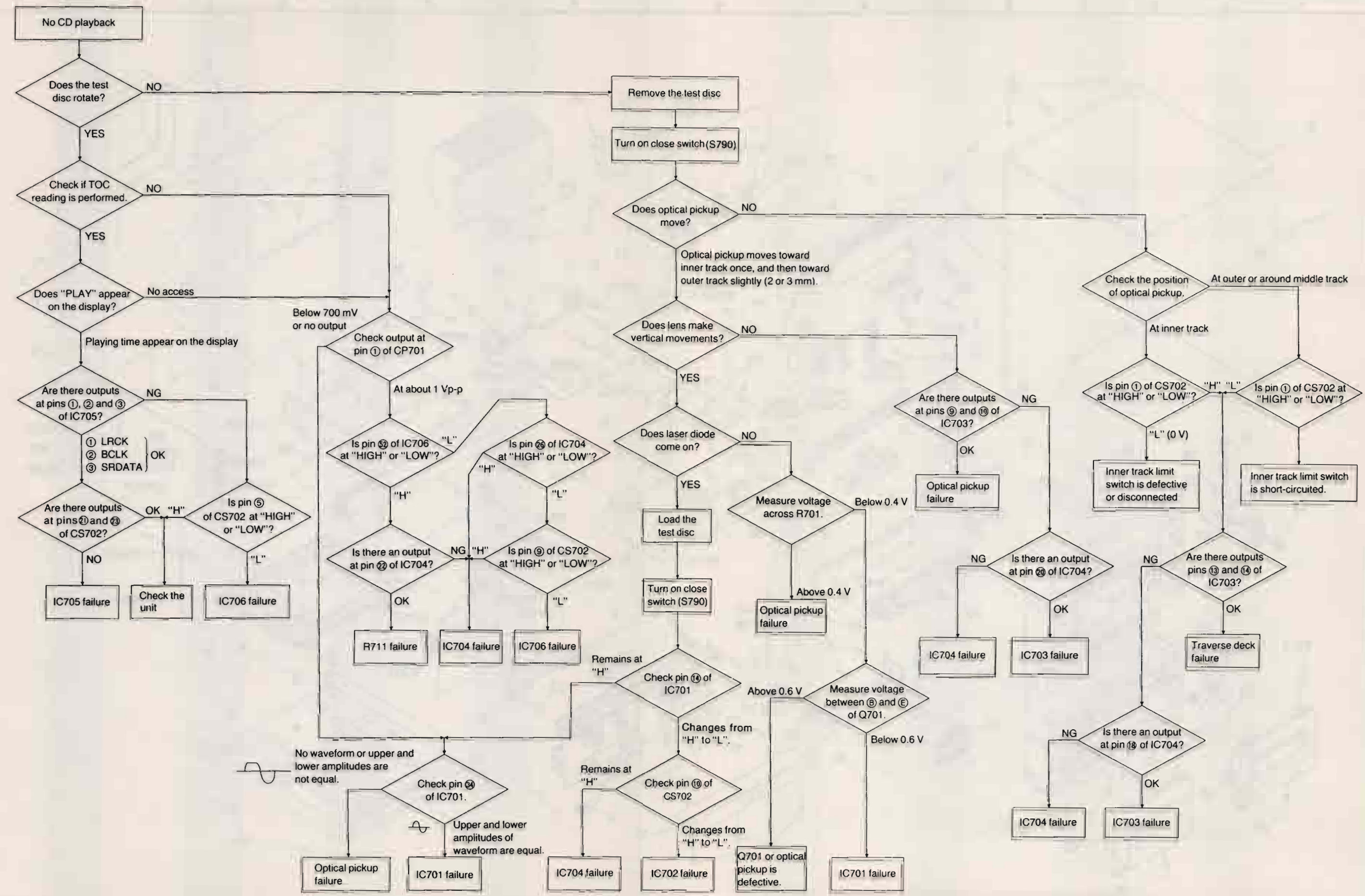

CABINET PARTS LOCATION

1 2 3 4 5 6 7 8 9 10

A

B

C

D

E

F

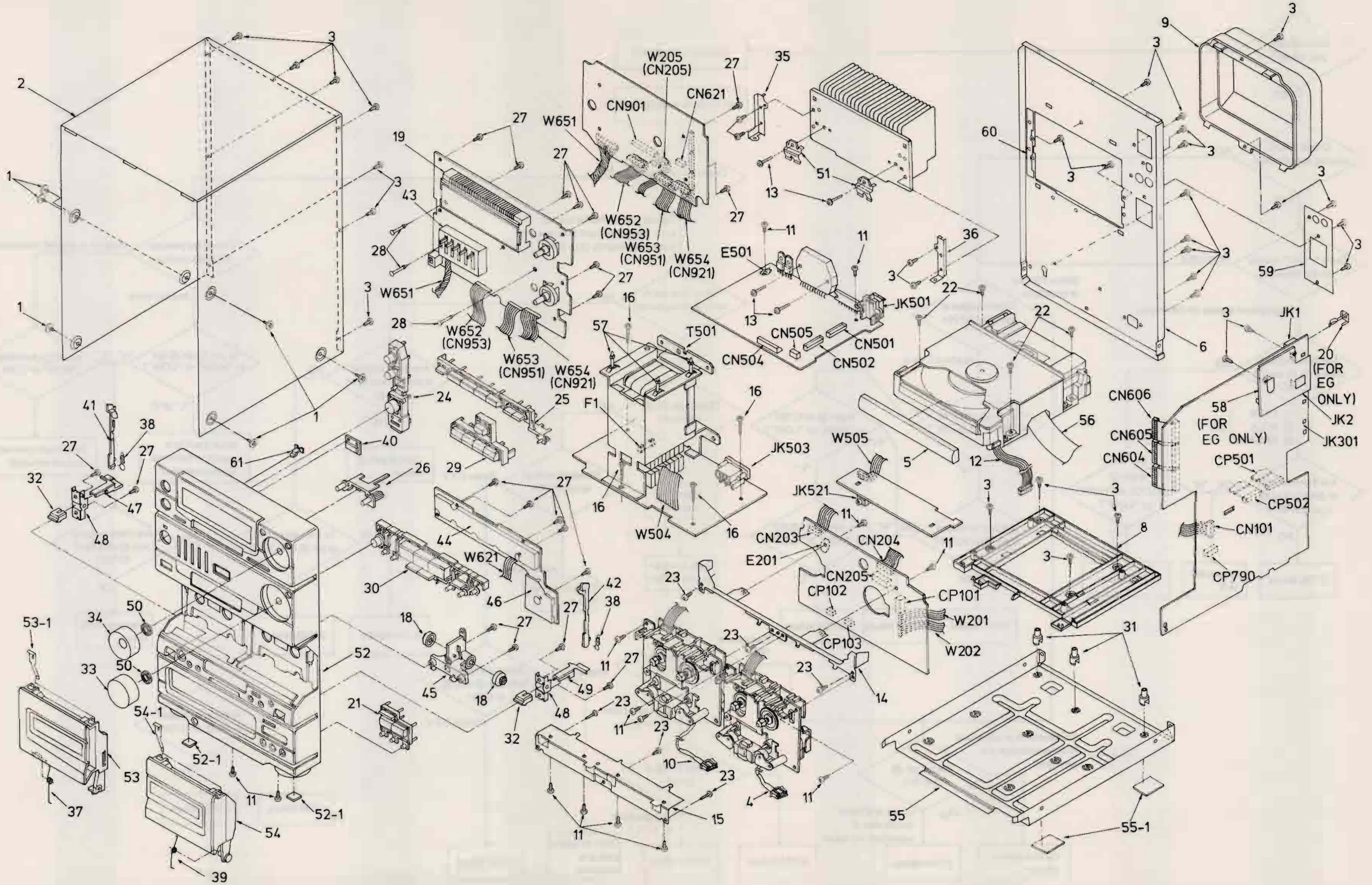

REPLACEMENT PARTS LIST

Notes : * Important safety notice:

 Components identified by \triangle mark have special characteristics important for safety.

Furthermore, special parts which have purposes of fire-retardant (resistors), high-quality sound (capacitors), low-noise (resistors), etc. are used.

When replacing any of components, be sure to use only manufacturer's specified parts shown in the parts list.

* The parenthesized indications in the Remarks columns specify the areas. (refer to the cover page for area.)

Parts without these indications can be used for all areas.

[M] Indicates in Remarks columns parts that are supplied by MESA.

Ref. No	Part No.	Part Name & Description	Remarks	Ref. No	Part No.	Part Name & Description	Remarks
				37	RMB0237	CASS. OPEN SPRING L	[M]
		CABINET & CHASSIS		38	RMB0239	EJECT ROD SPRING	[M]
				39	RMB0238	CASS. OPEN SPRING R	[M]
1	RHD30007	SCREW		40	RKW0209-Q	SENSOR WINDOW	[M]
2	RFKKACH11EBK	TOP CABINET ASS'Y	[M]	41	RMM0087	EJECT ROD L	[M]
3	XTB3+8JFZ	SCREW		42	RMM0088	EJECT ROD R	[M]
4	REX0305	R/P HEAD WIRE	[M]	43	RSC0270	GEQ SHIELD PLATE	[M]
5	RGK0473-K	CD LID	[M]	44	RSC0271	CASSETTE SHIELD PLATE	[M]
6	RGR0141B-F	REAR PANEL	[M] (E)	45	RMS0352	DAMPER GEAR HOLDER	[M]
6	RGR0141B-G	REAR PANEL	[M] (EB)	46	RSC0272	CD SHIELD PLATE	[M]
6	RGR0141B-E	REAR PANEL	[M] (EG)	47	RML0252	EJECT LEVER L	[M]
6	RGR0141B-H	REAR PANEL	[M] (GN)	48	RML0254	EJECT LEVER STAND	[M]
8	RMR0535-W	CD SUPPORT	[M]	49	RML0253	EJECT LEVER R	[M]
9	RMV0047	HEAT SINK COVER	[M]	50	SNE4021	NUT	
10	REX0450	WIRE ASS'Y	[M]	51	RMC0158-S	TRANSISTOR HOLDER	[M]
11	XTV26+6F	SCREW		52	RFKGACH11EBK	FRONT PANEL ASS'Y	[M]
12	REX0435	WIRE ASS'Y	[M]	52-1	SHS3276	LEG FELT (5MM)	[M]
13	XTW3+15T	SCREW		53	RFKLACH11EBA	CASS. LID (L) ASS'Y	[M]
14	RMA0570	CASSETTE ANGLE/UPPER	[M]	53-1	RUS757ZAA	SPRING	[M]
15	RMA0571	CASSETTE ANGLE/LOWER	[M]	54	RFKLACH11EBB	CASS. LID (R) ASS'Y	[M]
16	XTB3+20J	SCREW		54-1	RUS757ZAA	SPRING	[M]
18	RDG0129	DAMPER GEAR	[M]	55	RFKJACH33PK	BOTTOM BOARD ASS'Y	[M]
19	RMN0180	LCD HOLDER	[M]	55-1	SHG1654-S	LEG FELT (1.6MM)	[M]
20	RMC0180	FTZ EARTH PLATE	[M] (EG)	56	REE0395	FFC	[M]
21	RGU0743-K	BUTTON, CD	[M]	57	SHR9755	POWER PCB SUPPORT	
22	XTB3+12JFZ	SCREW		58	RSC0279	TUNER SHIELD PLATE	[M](EG)
23	XTB3+12JFR	SCREW		59	RMQ0302	HEAT PROTECTOR	[M]
24	RGU0737-K	BUTTON, POWER/TIMER	[M]	60	RMQ0306	HEAT PROTECTOR SHEET	[M]
25	RGU0738-K	BUTTON, TUNER	[M]	61	RGL0162-C	PANEL LIGHT	[M]
26	RGU0741-K	BUTTON, SET/CANCEL	[M]				
27	XTBS26+10J	SCREW				WIRES	
28	SHR8005	PANEL PCB SUPPORT					
29	RGU0740-K	BUTTON, INPUT SEL.	[M]	W504	REX0451	WIRE ASS'Y	[M]
30	RGU0742-K	BUTTON, CASSETTE	[M]	W651	REX0434	WIRE ASS'Y	[M]
31	SHE187-3	TRANS PCB SUPPORT					
32	RGU0750-K	KNOB, EJECT	[M]				
33	RGW0148-K	KNOB, VOLUME	[M]				
34	RGW0147-K	KNOB, AI JOG	[M]				
35	RMA0575	HEAT SINK ANGLE L	[M]				
36	RMA0576	HEAT SINK ANGLE R	[M]				

Ref. No	Part No.	Part Name & Description	Remarks	Ref.-No	Part No.	Part Name & Description	Remarks
		INTEGRATED CIRCUITS		Q14	2SC2785FTA	TRANSISTOR	
				Q15	2SA933SSTA	TRANSISTOR	[M]
				Q16	2SA933SSTA	TRANSISTOR	[M]
IC1	AN7273W	IC, FM AM IF&DET		Q19	2SC2785FTA	TRANSISTOR	
IC2	LM7001	IC, PLL		Q21	2SA933SSTA	TRANSISTOR	[M]
IC3	AN7470	IC, FM MPX		Q22	2SC2785FTA	TRANSISTOR	
IC101	M51167BFP-E1	IC, REC/PLAY	[M]	Q101	2SJ40CDTA	TRANSISTOR	
IC102	BA7755	IC, ANALOG SW		Q102	2SJ40CDTA	TRANSISTOR	
IC103	CXA1102M-T4	IC, DOLBY		Q103	2SJ40CDTA	TRANSISTOR	
IC104	BU4066BF-E2	IC, ANALOG SW		Q104	2SJ40CDTA	TRANSISTOR	
IC105	BU2040F-E2	IC, I/O EXPANDER	[M]	Q105	RVTDTTC144TST	TRANSISTOR	[M]
IC301	BU4066BF-E2	IC, ANALOG SWITCH		Q106	RVTDTTC144TST	TRANSISTOR	[M]
IC302	BU4066BF-E2	IC, ANALOG SWITCH		Q107	RVTDTTC144TST	TRANSISTOR	[M]
IC304	BA4558FDXE2	IC, OP AMP	[M]	Q108	RVTDTTC144TST	TRANSISTOR	[M]
IC307	BU2040F-E2	IC, I/O EXPANDER	[M]	Q109	RVTDTTC144TST	TRANSISTOR	[M]
IC501	SVI3101C	IC, POWER AMPLIFIER	△	Q110	RVTDTTC144TST	TRANSISTOR	[M]
IC502	BA3920	IC, REGULATOR	△	Q115	2SD1450STA	TRANSISTOR	
IC551	UPC4570HA	IC, OP AMP	[M]	Q116	2SD1302STA	TRANSISTOR	
IC552	UPC4570HA	IC, OP AMP	[M]	Q117	BA1L4MTA	TRANSISTOR	[M]
IC651	M5226FPE2	IC, G.EQ		Q151	RVTDTTC144TST	TRANSISTOR	[M]
IC652	M5226FPE2	IC, G.EQ		Q152	RVTDTTC144TST	TRANSISTOR	[M]
IC801	M51131L-702	IC, ELECTRONIC VOLUME		Q153	2SC1740SLNET	TRANSISTOR	
IC802	BA4558FDXE2	IC, OP AMP	[M]	Q154	2SC1740SLNET	TRANSISTOR	
IC901	MND2410RLAB2	IC, MICRO COM	[M]	Q171	2SD1302STA	TRANSISTOR	
IC902	BA4558FDXE2	IC, OP AMP	[M]	Q173	RVTDTTC144TST	TRANSISTOR	[M]
IC951	DN6851ALB	IC, HALL (DECK 1)		Q174	2SC2785FTA	TRANSISTOR	
IC971	DN6851ALB	IC, HALL (DECK 2)		Q175	2SD1302STA	TRANSISTOR	
		IC PROTECTOR		Q176	2SD1302STA	TRANSISTOR	
				Q179	2SC2784FTA	TRANSISTOR	
				Q180	2SC2784FTA	TRANSISTOR	
ICP301	SRUN20T	IC PROTECTOR		Q201	2SD965RTA	TRANSISTOR	
		TRANSISTORS		Q202	2SK301QTA	TRANSISTOR	[M]
				Q203	2SD965RTA	TRANSISTOR	
				Q204	2SK301QTA	TRANSISTOR	[M]
Q1	2SC2787LTA	TRANSISTOR		Q205	RVTDTTC144TST	TRANSISTOR	[M]
Q1T	2SK544F-AC	TRANSISTOR	(E/EB/GN)	Q206	2SB621RTA	TRANSISTOR	
Q2	2SC2787LTA	TRANSISTOR		Q207	2SB621RTA	TRANSISTOR	
Q2T	2SC2786MTA	TRANSISTOR	(E/EB/GN)	Q208	BA1A4ZTA	TRANSISTOR	[M]
Q3	2SC1740SQSTA	TRANSISTOR		Q209	BA1A4ZTA	TRANSISTOR	[M]
Q3T	2SC1675FL1LA	TRANSISTOR	(E/EB/GN)	Q210	2SC2785FTA	TRANSISTOR	
Q4	2SC2785FTA	TRANSISTOR		Q211	2SC2785FTA	TRANSISTOR	
Q4T	2SC1675FL1LA	TRANSISTOR	(E/EB/GN)	Q212	2SC2785FTA	TRANSISTOR	
Q5	2SA933SSTA	TRANSISTOR	[M]	Q213	2SC2785FTA	TRANSISTOR	
Q6	2SC1740SQSTA	TRANSISTOR		Q214	2SC2785FTA	TRANSISTOR	
Q7	2SC1740SQSTA	TRANSISTOR		Q215	2SC2785FTA	TRANSISTOR	
Q9	2SC2785FTA	TRANSISTOR		Q216	2SC2785FTA	TRANSISTOR	
Q10	2SC2785FTA	TRANSISTOR		Q217	2SC2785FTA	TRANSISTOR	
Q11	2SC2785FTA	TRANSISTOR		Q218	2SD1302STA	TRANSISTOR	

Ref. No	Part No.	Part Name & Description	Remarks	Ref. No	Part No.	Part Name & Description	Remarks
Q219	BN1L3NTA	TRANSISTOR	[M]	Q954	BN1A4MTA	TRANSISTOR	[M]
Q220	BN1L3NTA	TRANSISTOR	[M]	Q955	BA1A4MTA	TRANSISTOR	[M]
Q303	2SC2001KTA	TRANSISTOR					
Q304	2SC2001KTA	TRANSISTOR				DIODES	
Q305	2SC2785FTA	TRANSISTOR					
Q306	2SC2785FTA	TRANSISTOR		D1	RVD1SS133TA	DIODE	
Q307	RVTDTA114EST	TRANSISTOR		D1T	SVC211SPA-AL	DIODE	(E/EB/GN)
Q311	RVTDTA114EST	TRANSISTOR		D2	RVD1SS133TA	DIODE	
Q312	RVTDTA114EST	TRANSISTOR	[M]	D2T	SVC211SPA-AL	DIODE	(E/EB/GN)
Q320	RVTDTA143XST	TRANSISTOR		D3	RVD1SS133TA	DIODE	
Q321	RVTDTA143XST	TRANSISTOR		D3T	SVC211SPA-AL	DIODE	(E/EB/GN)
Q322	RVTDTA143XST	TRANSISTOR		D4	RVD1SS133TA	DIODE	
Q323	2SC2785FTA	TRANSISTOR		D171	RVD1SS133TA	DIODE	
Q324	2SC2785FTA	TRANSISTOR		D172	RVDMTZ4R7BTA	DIODE	
Q325	2SC2785FTA	TRANSISTOR		D173	RVD1SS133TA	DIODE	
Q451	2SC2785FTA	TRANSISTOR		D174	RVDMTZ3R6BTA	DIODE	[M]
Q452	2SC2785FTA	TRANSISTOR		D201	RVD1SS133TA	DIODE	
Q453	2SC2785FTA	TRANSISTOR		D202	RVD1SS133TA	DIODE	
Q454	2SC2785FTA	TRANSISTOR		D301	RVDMTZ6R2BTA	DIODE	
Q455	2SD2037EFTA	TRANSISTOR		D307	RVD1SS133TA	DIODE	
Q501	2SB1357ETA	TRANSISTOR	[M]	D308	RVD1SS133TA	DIODE	
Q503	2SD2037EFTA	TRANSISTOR		D315	RVD1SS133TA	DIODE	
Q504	2SC2785FTA	TRANSISTOR		D316	RVD1SS133TA	DIODE	
Q505	2SD1762F	TRANSISTOR		D317	RVD1SS133TA	DIODE	
Q506	2SB1185E	TRANSISTOR		D318	RVD1SS133TA	DIODE	
Q509	2SC2785FTA	TRANSISTOR		D319	RVD1SS133TA	DIODE	
Q519	2SB1185E	TRANSISTOR		D320	RVD1SS133TA	DIODE	
Q520	2SD592RTA	TRANSISTOR		D321	RVD1SS133TA	DIODE	
Q521	2SB621RTA	TRANSISTOR		D322	RVD1SS133TA	DIODE	
Q551	2SA564QTA	TRANSISTOR		D323	RVD1SS133TA	DIODE	
Q552	2SA564QTA	TRANSISTOR		D324	RVD1SS133TA	DIODE	
Q581	2SC2785FTA	TRANSISTOR		D451	RVDMTZ8R2CTA	DIODE	[M]
Q582	2SC2785FTA	TRANSISTOR		D453	RVDMTZ6R8BTA	DIODE	
Q801	2SK301QTA	TRANSISTOR	[M]	D502	RVDMTZ6R8ATA	DIODE	[M]
Q802	2SK301QTA	TRANSISTOR	[M]	D503	1SR35200TB	DIODE	
Q803	2SC1740SLNST	TRANSISTOR		D504	1SR35200TB	DIODE	
Q804	2SC1740SLNST	TRANSISTOR		D505	1SR35200TB	DIODE	
Q805	2SC2001KTA	TRANSISTOR		D506	1SR35200TB	DIODE	
Q806	2SC2001KTA	TRANSISTOR		D507	RVDMTZ15CTA	DIODE	[M]
Q807	2SC2001KTA	TRANSISTOR		D508	RVDMTZ15CTA	DIODE	[M]
Q808	2SC2001KTA	TRANSISTOR		D509	RVD1SS133TA	DIODE	
Q810	RVTDTA114EST	TRANSISTOR		D510	1D3E	DIODE	[M]
Q811	RVTDTA114EST	TRANSISTOR		D511	RL154M11	DIODE	[M]
Q812	RVTDTA114EST	TRANSISTOR	[M]	D512	RL154M11	DIODE	[M]
Q901	2SC2785FTA	TRANSISTOR		D513	RL154M11	DIODE	[M]
Q902	2SC2785FTA	TRANSISTOR		D514	RL154M11	DIODE	[M]
Q903	BA1L4MTA	TRANSISTOR	[M]	D515	RVD1SS133TA	DIODE	
Q952	BA1L4MTA	TRANSISTOR	[M]	D519	RVD1SS133TA	DIODE	

Ref. No	Part No.	Part Name & Description	Remarks	Ref. No	Part No.	Part Name & Description	Remarks
D520	RVDMTZ15CTA	DIODE	[M]				
D521	RVD1SS133TA	DIODE				COMPONENT COMBINATION	
D522	RVD1SS133TA	DIODE					
D523	RVDMTZ5R1CTA	DIODE		Z1	ENV17283G1	TUNER PACK	[M] (EG)
D524	RVD1SS133TA	DIODE		Z2	RLA6Z002-T	MW/LW COIL BLOCK	
D525	RVD1SS133TA	DIODE		Z3	RLI2Z003-T	AM IF BLOCK	[M]
D526	RVD1SS133TA	DIODE		Z101	EXBF6L306SYV	COMPONENT COMBINATION	
D821	RVD1SS133TA	DIODE		Z102	EXBF6L306SYV	COMPONENT COMBINATION	
D822	RVD1SS133TA	DIODE		Z103	EXBF6L306SYV	COMPONENT COMBINATION	
D901	ISS291TA	DIODE		Z901	RCDHC-278	REMOTE SENSOR	
D903	RVD1SS133TA	DIODE		Z902	RSL5065-L	LCD	[M]
D904	RVD1SS133TA	DIODE					
D905	RVD1SS133TA	DIODE				COILS & TRANSFORMERS	
D906	RVD1SS133TA	DIODE					
D907	RVD1SS133TA	DIODE		L1	RLQZP1R2KT-Y	COIL	(EG)
D908	RVD1SS133TA	DIODE		L2	ELEPKR22MA	COIL	
D909	RVD1SS133TA	DIODE		L2T	RLQZP1R2KT-Y	COIL	(E/EB/GN)
D910	RVD1SS133TA	DIODE		L3	ELEPKR22MA	COIL	
D951	RVDMTZ8R2BTA	DIODE (DECK)		L4	RLQZPR82KT-Y	COIL	
D951	RVD1SS133TA	DIODE		L4T	RLQZP1R2KT-Y	COIL	(E/EB/GN)
D952	SLR33VC160	LED	[M]	L5	RLQZP1R2KT-Y	COIL	
D953	RVD1SS133TA	DIODE		L6	SLM1B10-1M	A.B.FILTER	
D954	RVD1SS133TA	DIODE		L7	RLM2B003-K	MPX FILTER	
D955	RVD1SS133TA	DIODE		L8	RLM2B003-K	MPX FILTER	
D960	LN123594P	LED	[M]	L101	RLE9B001-1M	COIL	[M]
D971	RVD1SS133TA	DIODE (DECK)		L102	RLE9B001-1M	COIL	[M]
				L103	RLE2B001-1M	COIL	[M]
		VARIABLE RESISTORS		L104	RLE2B001-1M	COIL	[M]
				L201	RL08C002-T	COIL	
VR1	EVNDXAA00B53	VR, VCO		L202	RLQZB470KT-D	COIL	
VR101-104	RVNCC24B1T-A	VR, PB GAIN ADJ.		L301	RLQZB4R7KT-D	COIL	[M]
VR201	RVNCC73B1T-A	VR, TAPE SPEED ADJ.		L501	SLQY07G-40	COIL	
VR202	RVNCC24B1T-A	VR, TAPE SPEED ADJ.		L502	SLQY07G-40	COIL	
VR203	RVNCC14B1T-A	VR, HIGH SPEED ADJ.		L503	RLQZ600-W	AC LINE FILTER	[M] ⚠
VR651	EWAJQAW05G54	VR, GEQ. 10 kHz	[M]	L901	RLQZP3R3KT-Y	COIL	
VR652	EWAJQAW05G54	VR, GEQ. 3.3 kHz	[M]	L902	RLQZP2R2KT-Y	COIL	
VR653	EWAJQAW05G54	VR, GEQ. 1 kHz	[M]	L903	RLQZP2R2KT-Y	COIL	
VR654	EWAJQAW05G54	VR, 330 Hz	[M]	L904	RLQZP2R2KT-Y	COIL	
VR655	EWAJQAW05G54	VR, 100 Hz	[M]	L905	RLQZP2R2KT-Y	COIL	
VR901	EVQWPJF1524B	VR, AI JOG	[M]	T1	RLI4B002-Z	FM DET COIL	
VR902	EVQWQAF1524B	VR, MAIN VOL	[M]	T2	RLI4B003-Z	FM DET COIL	
				T501	RTP1M3B003-X	POWER TRANSFORMER	[M] ⚠
		RELAY					
						CERAMIC FILTERS	
RLY501	RSY0007-C	RELAY	⚠				
				CF1	RLFFETNGA01L	CERAMIC FILTER	
				CF2	RLFFETNGA02L	CERAMIC FILTER	

Ref. No	Part No.	Part Name & Description	Remarks	Ref. No	Part No.	Part Name & Description	Remarks
		OSCILLATORS		S633	EVQ21405R	SW, CD STOP	
				S634	EVQ21405R	SW, CD PLAY	
				S635	EVQ21405R	SW, CD PAUSE	
X1	SVQ49U722T-S	OSCILLATOR		S636	EVQ21405R	SW, F. SKIP	
X901	RSXZ4M19M01T	OSCILLATOR	[M]	S637	EVQ21405R	SW, R. SKIP	
X902	RSXD32K7S02	OSCILLATOR	[M]	S638	EVQ21405R	SW, OPEN/CLOSE	
		FUSE		S951	RSH1A89ZB-U	SW, MODE (DECK 1)	
				S952	RSH1A90YB-U	SW, HALF (DECK 1)	
				S953	RSH1A90YB-U	SW, ATS (DECK 1)	
F1	XBA2C05TB0	FUSE	△	S971	RSH1A89ZB-U	SW, MODE (DECK 2)	
		FUSE CLIPS		S972	RSH1A90YB-U	SW, HALF (DECK 2)	
				S973	RSH1A90YB-U	SW, R. REC INHL (DECK 2)	
FC1	EYF52BC	FUSE CLIP		S974	RSH1A90YB-U	SW, F. REC INHL (DECK 2)	
FC2	EYF52BC	FUSE CLIP		S975	RSH1A90YB-U	SW, ATS (DECK 2)	
				S976	RSH1A90YB-U	SW, ATS (DECK 2)	
		SWITCHES				JACKS	
S601	EVQ21405R	SW, TUNER		JK1	RJH8201	JACK, ANT. TERMINAL	[M](E,EB,EG)
S602	EVQ21405R	SW, CD		JK1	RJH5301	JACK, ANT. TERMINAL	[M](GN)
S603	EVQ21405R	SW, AUX		JK2	SJS208	JACK, LOOP ANT. TERMINAL	
S604	EVQ21405R	SW, TAPE		JK301	SJF3068N	JACK, RCA TERMINAL	
S605	EVQ21405R	SW, SUPER BASS		JK501	SJF5406-1	JACK, SP TERMINAL	[M]
S606	EVQ21405R	SW, POWER		JK503	SJS9236	JACK, AC INLET	(E,EB,EG)△
S607	EVQ21405R	SW, PLAYER TIMER		JK503	SJSD16	JACK, AC INLET	(GN)△
S608	EVQ21405R	SW, REC TIMER		JK521	RJJD7S2YA-C	JACK, HEADPHONE	
S609	EVQ21405R	SW, VOL PRESET				EARTH TERMINAL	
S610	EVQ21405R	SW, SET					
S611	EVQ21405R	SW, CANCEL		E1	SNE1004-1	EARTH TERMINAL	(EG)
S612	EVQ21405R	SW, FM MODE/BP		E2	SNE1004-1	EARTH TERMINAL	(EG)
S613	EVQ21405R	SW, BAND		E201	SNE1004-1	EARTH TERMINAL	
S614	EVQ21405R	SW, TUNING		E501	SNE1004-1	EARTH TERMINAL	
S615	EVQ21405R	SW, CD EDIT				CONNECTORS	
S616	EVQ21405R	SW, DISPLAY					
S617	EVQ21405R	SW, CLOCK/TIMER		CN101	RHR196ZA	WIRE HOLDER	
S618	EVQ21405R	SW, SLEEP		CN103	RJS9T4ZA	SOCKET	
S621	EVQ21405R	SW, REV MODE		CN203	RHR197ZA	WIRE HOLDER	
S622	EVQ21405R	SW, COUNTER RESET		CN204	RHR194ZA	WIRE HOLDER	
S623	EVQ21405R	SW, DOLBY		CN205	RHR195ZA	WIRE HOLDER	
S624	EVQ21405R	SW, REC PAUSE		CN501	RJU005A012	SOCKET	
S625	EVQ21405R	SW, NORMAL		CN502	RJU005A012	SOCKET	
S626	EVQ21405R	SW, HIGH		CN504	RJP12G9YA	CONNECTOR	
S627	EVQ21405R	SW, STOP		CN505	RJS5T5ZA	SOCKET	
S628	EVQ21405R	SW, REW		CN510	RJS1A1101T1	CONNECTOR	
S629	EVQ21405R	SW, R. PLAY		CN511	RJS1A1101T1	CONNECTOR	
S630	EVQ21405R	SW, F. PLAY		CN512	RJS1A1101T1	CONNECTOR	
S631	EVQ21405R	SW, FF					
S632	EVQ21405R	SW, DECK 1/2					

Ref. No.	Part No.	Values & Remarks	Ref. No.	Part No.	Values & Remarks	Ref. No.	Part No.	Values & Remarks
R154	ERDS2TJ102T	1K 1/4W	R222	ERDS2TJ473T	47K 1/4W	R341	ERDS2TJ103T	10K 1/4W
R155	ERDS2TJ221T	220 1/4W	R223	ERDS2TJ472T	4.7K 1/4W	R342	ERDS2TJ104T	100K 1/4W
R156	ERDS2TJ221T	220 1/4W	R224	ERDS2TJ103T	10K 1/4W	R343	ERDS2TJ103T	10K 1/4W
R158	ERDS2TJ101T	100 1/4W	R225	ERDS2TJ2R7T	2.7 1/4W	R344	ERDS2TJ472T	4.7K 1/4W
R159	ERDS2TJ222T	2.2K 1/4W	R226	ERDS2TJ102T	1K 1/4W	R359	ERDS2TJ122T	1.2K 1/4W
R160	ERDS2TJ222T	2.2K 1/4W	R227	ERDS2TJ102T	1K 1/4W	R360	ERDS2TJ122T	1.2K 1/4W
R161	ERDS2TJ472T	4.7K 1/4W	R228	ERDS2TJ472T	4.7K 1/4W	R364	ERDS2TJ183T	18K 1/4W
R162	ERDS2TJ472T	4.7K 1/4W	R229	ERDS2TJ103T	10K 1/4W	R371	ERDS2TJ102T	1K 1/4W
R163	ERDS2TJ433T	43K 1/4W	R230	ERDS2TJ472T	4.7K 1/4W	R372	ERDS2TJ102T	1K 1/4W
R169	ERDS2TJ102T	1K 1/4W	R231	ERDS2TJ472T	4.7K 1/4W	R373	ERDS2TJ103T	10K 1/4W
R170	ERDS2TJ102T	1K 1/4W	R232	ERDS2TJ102T	1K 1/4W	R374	ERDS2TJ103T	10K 1/4W
R172	ERDS2TJ331T	330 1/4W	R233	ERDS2TJ222T	2.2K 1/4W	R376	ERDS2TJ103T	10K 1/4W
R173	ERDS2TJ103T	10K 1/4W	R234	ERDS2TJ472T	4.7K 1/4W	R377	ERDS2TJ222T	2.2K 1/4W
R174	ERDS2TJ472T	4.7K 1/4W	R235	ERDS2TJ104T	100K 1/4W	R379	ERDS2TJ104T	100K 1/4W
R176	ERDS2TJ822T	8.2K 1/4W	R236	ERDS2TJ104T	100K 1/4W	R380	ERDS2TJ104T	100K 1/4W
R177	ERDS2TJ103T	10K 1/4W	R237	ERDS2TJ100T	10 1/4W	R381	ERDS2TJ392T	3.9K 1/4W
R178	ERDS2TJ1R2T	1.2 1/4W	R301	ERDS2TJ223T	22K 1/4W	R382	ERDS2TJ103T	10K 1/4W
R179	ERDS2TJ472T	4.7K 1/4W	R302	ERDS2TJ223T	22K 1/4W	R383	ERDS2TJ103T	10K 1/4W
R180	ERDS2TJ472T	4.7K 1/4W	R303	ERDS2TJ222T	2.2K 1/4W	R384	ERDS2TJ823T	82K 1/4W
R181	ERDS2TJ332T	3.3K 1/4W	R304	ERDS2TJ222T	2.2K 1/4W	R389	ERDS2TJ822T	8.2K 1/4W
R182	ERDS2TJ1R0T	1 1/4W	R305	ERDS2TJ222T	2.2K 1/4W	R390	ERDS2TJ272T	2.7K 1/4W
R183	ERDS2TJ104T	100K 1/4W	R306	ERDS2TJ222T	2.2K 1/4W	R391	ERDS2TJ332T	3.3K 1/4W
R184	ERDS2TJ104T	100K 1/4W	R308	ERDS2TJ334T	330K 1/4W	R392	ERDS2TJ103T	10K 1/4W
R185	ERDS2TJ104T	100K 1/4W	R309	ERDS2TJ222T	2.2K 1/4W	R393	ERDS2TJ103T	10K 1/4W
R186	ERDS2TJ102T	1K 1/4W	R311	ERDS2TJ152T	1.5K 1/4W	R394	ERDS2TJ103T	10K 1/4W
R188	ERDS2TJ102T	1K 1/4W	R312	ERDS2TJ121T	120 1/4W	R395	ERDS2TJ103T	10K 1/4W
R189	ERDS2TJ472T	4.7K 1/4W	R313	ERDS2TJ682T	6.8K 1/4W	R397	ERDS2TJ563T	56K 1/4W
R200	ERDS2TJ221T	220 1/4W	R314	ERDS2TJ682T	6.8K 1/4W	R398	ERDS2TJ563T	56K 1/4W
R201	ERDS2TJ2R7T	2.7 1/4W	R315	ERDS2TJ273T	27K 1/4W	R401	ERDS2TJ181T	180 1/4W
R202	ERDS2TJ562T	5.6K 1/4W	R316	ERDS2TJ273T	27K 1/4W	R402	ERDS2TJ181T	180 1/4W
R203	ERDS2TJ153T	15K 1/4W	R317	ERDS2TJ562T	5.6K 1/4W	R403	ERDS2TJ181T	180 1/4W
R204	ERDS2TJ123T	12K 1/4W	R318	ERDS2TJ562T	5.6K 1/4W	R404	ERDS2TJ181T	180 1/4W
R205	ERDS2TJ334T	330K 1/4W	R319	ERDS2TJ223T	22K 1/4W	R451	ERDS2TJ273T	27K 1/4W
R206	ERDS2TJ221T	220 1/4W	R320	ERDS2TJ223T	22K 1/4W	R452	ERDS2TJ273T	27K 1/4W
R207	ERDS2TJ2R7T	2.7 1/4W	R321(EB/GN)	ERDS2TJ222T	2.2K 1/4W	R453	ERDS2TJ102T	1K 1/4W
R208	ERDS2TJ123T	12K 1/4W	R321(EG)	ERDS2TJ392T	3.9K 1/4W	R454	ERDS2TJ102T	1K 1/4W
R209	ERDS2TJ123T	12K 1/4W	R322(EB/GN)	ERDS2TJ222T	2.2K 1/4W	R455	ERDS2TJ222T	2.2K 1/4W
R210	ERDS2TJ272T	2.7K 1/4W	R322(EG)	ERDS2TJ392T	3.9K 1/4W	R456	ERDS2TJ222T	2.2K 1/4W
R211	ERDS2TJ334T	330K 1/4W	R323	ERDS2TJ103T	10K 1/4W	R457	ERDS2TJ821T	820 1/4W
R212	ERDS2TJ123T	12K 1/4W	R324	ERDS2TJ103T	10K 1/4W	R458	ERDS2TJ821T	820 1/4W
R213	ERDS2TJ152T	1.5K 1/4W	R325	ERDS2TJ392T	3.9K 1/4W	R459	ERDS2TJ102T	1K 1/4W
R215	ERDS2TJ472T	4.7K 1/4W	R326	ERDS2TJ105T	1M 1/4W	R460	ERDS2TJ102T	1K 1/4W
R216	ERDS2TJ473T	47K 1/4W	R327	ERDS2TJ153T	15K 1/4W	R461	ERDS2TJ101T	100 1/4W
R217	ERDS2TJ473T	47K 1/4W	R328	ERDS2TJ153T	15K 1/4W	R462	ERDS2TJ472T	4.7K 1/4W
R218	ERDS2TJ473T	47K 1/4W	R329	ERDS2TJ154T	150K 1/4W	R463	ERDS2TJ104T	100K 1/4W
R219	ERDS2TJ103T	10K 1/4W	R330	ERDS2TJ154T	150K 1/4W	R464	ERDS2TJ104T	100K 1/4W
R220	ERDS2TJ472T	4.7K 1/4W	R339	ERDS2TJ332T	3.3K 1/4W	R465	ERDS2TJ104T	100K 1/4W
R221	ERDS2TJ2R7T	2.7 1/4W	R340	ERDS2TJ332T	3.3K 1/4W	R466	ERDS2TJ222T	2.2K 1/4W

Ref. No	Part No.	Part Name & Description	Remarks	Ref. No	Part No.	Part Name & Description	Remarks
CN513	RJS1A1101T1	CONNECTOR					
CN514	RJS1A1101T1	CONNECTOR				VARIABLE RESISTOR	
CN515	RJS1A1101T1	CONNECTOR					
CN516	RJS1A1101T1	CONNECTOR		VR701	EVNDXAA00B14	VR, BEST EYE ADJ.	
CN517	RJS1A1101T1	CONNECTOR					
CN518	RJS1A1101T1	CONNECTOR				OSCILLATOR	
CN604	RJU005A012	CONNECTOR					
CN605	RJU005A012	CONNECTOR		X701	RSXZ33M8M01T	OSCILLATOR	
CN606	RJU005A012	CONNECTOR					
CN621	RJS4T5ZA	SOCKET				SWITCHES	
CN901	RJS1A6823	CONNECTOR					
CN921	RHR199ZA	WIRE HOLDER		S790	RSH1A005	SW, DISC TRAY CLOSE	
CN951	RHR199ZA	WIRE HOLDER		S791	RSH1A005	SW, DISC TRAY OPEN	
CN953	RHR199ZA	WIRE HOLDER					
CP1T	SJT30839MB	CONNECTOR	(E/EB/GN)				
CP2T	SJT30739MB	CONNECTOR	(E/EB/GN)				
CP101	RJP5G18ZA	CONNECTOR					
CP102	RJP4G18ZA	CONNECTOR					
CP205	RJS8T4ZA	SOCKET					
CP501	RJT005W012	CONNECTOR	[M]				
CP502	RJT005W012	CONNECTOR	[M]				
CP604	RJT005W012	CONNECTOR	[M]				
CP605	RJT005W012	CONNECTOR	[M]				
CP606	RJT005W012	CONNECTOR	[M]				
CP790	RJP6G18ZA	CONNECTOR					
		< SERVO P.C.B. >					
		INTEGRATED CIRCUITS					
IC701	AN8800SCE2	IC, SERVO AMP.					
IC702	TCA0372DM2R	IC, SPINDLE MOTOR DR.					
IC703	AN8377N	IC, TRAVERSE MOTOR DR.					
IC704	MN6650	IC, DIGITAL SERVO PRO.					
IC705	MN6475	IC, DIGITAL FILTER					
IC706	MN6626	IC, DIGITAL SIGNAL PRO.					
IC709	JA7291S	IC, MOTOR DRIVE					
		TRANSISTOR					
Q701	2SB709	TRANSISTOR					
		DIODE					
D701	MA1101W	DIODE					

RESISTORS & CAPACITORS

Notes : * Capacitor values are in microfarad (μF) unless specified otherwise, P=Pico-farads (pF) F=Farads (F)
 * Resistors values are in ohms, unless specified otherwise, 1k=1,000(OHM), 1M=1,000k(OHM)

Ref. No.	Part No.	Values & Remarks	Ref. No.	Part No.	Values & Remarks	Ref. No.	Part No.	Values & Remarks
	RESISTORS							
R1(E/EB/GN)	ERDS2TJ122T	1.2K 1/4W	R29	ERDS2TJ122T	1.2K 1/4W	R103	ERDS2TJ123T	12K 1/4W
R1(EG)	ERDS2TJ272T	2.7K 1/4W	R30	ERDS2TJ103T	10K 1/4W	R104	ERDS2TJ123T	12K 1/4W
R1T(E/EB/GN)	ERDS2TJ104T	100K 1/4W	R31	ERDS2TJ562T	5.6K 1/4W	R105	ERDS2TJ181T	180 1/4W
R2	ERDS2TJ684T	680K 1/4W	R32	ERDS2TJ561T	560 1/4W	R106	ERDS2TJ222T	2.2K 1/4W
R2T(E/EB/GN)	ERDS2TJ104T	100K 1/4W	R33	ERDS2TJ102T	1K 1/4W	R107	ERDS2TJ330T	33 1/4W
R3	ERDS2TJ122T	1.2K 1/4W	R37	ERDS2TJ151T	150 1/4W	R108	ERDS2TJ330T	33 1/4W
R3T(E/EB/GN)	ERDS2TJ470T	47 1/4W	R38	ERDS2TJ103T	10K 1/4W	R109	ERDS2TJ392T	3.9K 1/4W
R4	ERDS2TJ824T	820K 1/4W	R39	ERDS2TJ103T	10K 1/4W	R110	ERDS2TJ392T	3.9K 1/4W
R4T(E/EB/GN)	ERDS2TJ104T	100K 1/4W	R40	ERDS2TJ103T	10K 1/4W	R111	ERDS2TJ222T	2.2K 1/4W
R5	ERDS2TJ391T	390 1/4W	R41	ERDS2TJ103T	10K 1/4W	R112	ERDS2TJ222T	2.2K 1/4W
R5T(E/EB/GN)	ERDS2TJ564T	560K 1/4W	R42	ERDS2TJ103T	10K 1/4W	R113	ERDS2TJ122T	1.2K 1/4W
R6	ERDS2TJ471T	470 1/4W	R43	ERDS2TJ104T	100K 1/4W	R114	ERDS2TJ122T	1.2K 1/4W
R6T(E/EB/GN)	ERDS2TJ391T	390 1/4W	R44	ERDS2TJ103T	10K 1/4W	R115	ERDS2TJ225T	2.2M 1/4W
R7	ERDS2TJ103T	10K 1/4W	R45	ERDS2TJ473T	47K 1/4W	R116	ERDS2TJ225T	2.2M 1/4W
R7T(E/EB/GN)	ERDS2TJ272T	2.7K 1/4W	R46	ERDS2TJ151T	150 1/4W	R117	ERDS2TJ105T	1M 1/4W
R8	ERDS2TJ684T	680K 1/4W	R47	ERDS2TJ103T	10K 1/4W	R118	ERDS2TJ105T	1M 1/4W
R8T(E/EB/GN)	ERDS2TJ681T	680 1/4W	R48	ERDS2TJ333T	33K 1/4W	R121	ERDS2TJ154T	150K 1/4W
R9	ERDS2TJ103T	10K 1/4W	R49	ERDS2TJ223T	22K 1/4W	R122	ERDS2TJ154T	150K 1/4W
R9T(E/EB/GN)	ERDS2TJ474T	470K 1/4W	R50	ERDS2TJ223T	22K 1/4W	R123	ERDS2TJ473T	47K 1/4W
R10	ERDS2TJ153T	15K 1/4W	R51	ERDS2TJ224T	220K 1/4W	R124	ERDS2TJ473T	47K 1/4W
R10T(E/EB/GN)	ERDS2TJ224T	220K 1/4W	R52	ERDS2TJ473T	47K 1/4W	R125	ERDS2TJ472T	4.7K 1/4W
R11	ERDS2TJ331T	330 1/4W	R53	ERDS2TJ473T	47K 1/4W	R126	ERDS2TJ472T	4.7K 1/4W
R11T(E/EB/GN)	ERDS2TJ391T	390 1/4W	R55(EG)	ERDS2TJ102T	1K 1/4W	R127	ERDS2TJ332T	3.3K 1/4W
R12	ERDS2TJ332T	3.3K 1/4W	R56	ERDS2TJ272T	2.7K 1/4W	R128	ERDS2TJ332T	3.3K 1/4W
R12T(E/EB/GN)	ERDS2TJ181T	180 1/4W	R57	ERDS2TJ272T	2.7K 1/4W	R129	ERDS2TJ103T	10K 1/4W
R13	ERDS2TJ102T	1K 1/4W	R58	ERDS2TJ562T	5.6K 1/4W	R130	ERDS2TJ103T	10K 1/4W
R14	ERDS2TJ822T	8.2K 1/4W	R59	ERDS2TJ562T	5.6K 1/4W	R131	ERDS2TJ823T	82K 1/4W
R15	ERDS2TJ222T	2.2K 1/4W	R60	ERDS2TJ102T	1K 1/4W	R132	ERDS2TJ335T	3.3M 1/4W
R16	ERDS2TJ561T	560 1/4W	R61	ERDS2TJ102T	1K 1/4W	R133	ERDS2TJ332T	3.3K 1/4W
R17	ERDS2TJ154T	150K 1/4W	R62	ERDS2TJ102T	1K 1/4W	R134	ERDS2TJ474T	470K 1/4W
R18	ERDS2TJ183T	18K 1/4W	R63	ERDS2TJ153T	15K 1/4W	R137	ERDS2TJ103T	10K 1/4W
R19	ERDS2TJ822T	8.2K 1/4W	R64	ERDS2TJ103T	10K 1/4W	R138	ERDS2TJ103T	10K 1/4W
R20	ERDS2TJ104T	100K 1/4W	R65	ERDS2TJ123T	12K 1/4W	R139	ERDS2TJ103T	10K 1/4W
R21	ERDS2TJ102T	1K 1/4W	R66	ERDS2TJ103T	10K 1/4W	R141	ERDS2TJ682T	6.8K 1/4W
R22	ERDS2TJ102T	1K 1/4W	R67	ERDS2TJ103T	10K 1/4W	R142	ERDS2TJ682T	6.8K 1/4W
R23	ERDS2TJ223T	22K 1/4W	R68	ERDS2TJ181T	180 1/4W	R143	ERDS2TJ222T	2.2K 1/4W
R24	ERDS2TJ103T	10K 1/4W	R71	ERDS2TJ104T	100K 1/4W	R144	ERDS2TJ222T	2.2K 1/4W
R25	ERDS2TJ182T	1.8K 1/4W	R72	ERDS2TJ824T	820K 1/4W	R145	ERDS2TJ103T	10K 1/4W
R26	ERDS2TJ152T	1.5K 1/4W	R73	ERDS2TJ223T	22K 1/4W	R146	ERDS2TJ103T	10K 1/4W
R27	ERDS2TJ103T	10K 1/4W	R74	ERDS2TJ682T	6.8K 1/4W	R149	ERDS2TJ272T	2.7K 1/4W
R28	ERDS2TJ122T	1.2K 1/4W	R75	ERDS2TJ562T	5.6K 1/4W	R150	ERDS2TJ272T	2.7K 1/4W
			R76(EG)	ERDS2TJ121T	120 1/4W	R151	ERDS2TJ105T	1M 1/4W
			R101	ERDS2TJ334T	330K 1/4W	R152	ERDS2TJ105T	1M 1/4W
			R102	ERDS2TJ104T	100K 1/4W	R153	ERDS2TJ102T	1K 1/4W

Ref. No.	Part No.	Values & Remarks	Ref. No.	Part No.	Value & Remarks	Ref. No.	Part No.	Values & Remarks
R467	ERDS2TJ222T	2.2K 1/4W	R548	ERX1SJR22E	0.22 1/2W Δ	R614	ERDS2TJ122T	1.2K 1/4W
R468	ERDS2TJ222T	2.2K 1/4W	R549	ERDS2TJ473T	47K 1/4W	R615	ERDS2TJ182T	1.8K 1/4W
R469	ERDS2TJ152T	1.5K 1/4W	R550	ERDS2TJ473T	47K 1/4W	R616	ERDS2TJ222T	2.2K 1/4W
R470	ERG1SJ100E	10 1W Δ	R551	ERDS2TJ104T	100K 1/4W	R617	ERDS2TJ272T	2.7K 1/4W
R501	ERDS2TJ102T	1K 1/4W	R552	ERDS2TJ104T	100K 1/4W	R618	ERDS2TJ472T	4.7K 1/4W
R502	ERDS2TJ102T	1K 1/4W	R553	ERDS2TJ223T	22K 1/4W	R619	ERDS2TJ682T	6.8K 1/4W
R503	ERDS2TJ682T	6.8K 1/4W	R554	ERDS2TJ223T	22K 1/4W	R620	ERDS2TJ103T	10K 1/4W
R504	ERDS2TJ682T	6.8K 1/4W	R555	ERDS2TJ223T	22K 1/4W	R621	ERDS2TJ223T	22K 1/4W
R505	ERDS2TJ683T	68K 1/4W	R556	ERDS2TJ223T	22K 1/4W	R623	ERDS2TJ103T	10K 1/4W
R506	ERDS2TJ683T	68K 1/4W	R557	ERDS2TJ103T	10K 1/4W	R624	ERDS2TJ102T	1K 1/4W
R507	ERDS2TJ683T	68K 1/4W	R558	ERDS2TJ103T	10K 1/4W	R625	ERDS2TJ102T	1K 1/4W
R508	ERDS2TJ683T	68K 1/4W	R559	ERDS2TJ223T	22K 1/4W	R626	ERDS2TJ122T	1.2K 1/4W
R509	ERD25FVJ470T	47 1/4W	R560	ERDS2TJ223T	22K 1/4W	R627	ERDS2TJ182T	1.8K 1/4W
R511	ERDS2TJ563T	56K 1/4W	R561	ERDS2TJ223T	22K 1/4W	R628	ERDS2TJ222T	2.2K 1/4W
R512	ERDS2TJ103T	10K 1/4W	R562	ERDS2TJ223T	22K 1/4W	R631	ERDS2TJ103T	10K 1/4W
R513	ERDS2TJ1R0T	1 1/4W	R563	ERDS2TJ393T	39K 1/4W	R632	ERDS2TJ102T	1K 1/4W
R514	ERDS1FVJ182T	1.8K 1/2W	R564	ERDS2TJ393T	39K 1/4W	R633	ERDS2TJ102T	1K 1/4W
R515	ERDS1FVJ100T	10 1/2W	R565	ERDS2TJ123T	12K 1/4W	R634	ERDS2TJ122T	1.2K 1/4W
R516	ERDS1FVJ100T	10 1/2W	R566	ERDS2TJ123T	12K 1/4W	R635	ERDS2TJ182T	1.8K 1/4W
R517	ERDS2TJ100T	10 1/4W	R567	ERDS2TJ104T	100K 1/4W	R636	ERDS2TJ222T	2.2K 1/4W
R518	ERDS2TJ100T	10 1/4W	R568	ERDS2TJ104T	100K 1/4W	R637	ERDS2TJ272T	2.7K 1/4W
R519	ERDS2TJ334T	330K 1/4W	R569	ERDS2TJ101T	100 1/4W	R638	ERDS2TJ472T	4.7K 1/4W
R521	ERDS1FVJ221T	220 1/2W Δ	R570	ERDS2TJ101T	100 1/4W	R639	ERDS2TJ682T	6.8K 1/4W
R522	ERDS1FVJ271T	270 1/2W Δ	R571	ERDS2TJ103T	10K 1/4W	R640	ERDS2TJ103T	10K 1/4W
R523	ERDS2TJ272T	2.7K 1/4W	R572	ERDS2TJ103T	10K 1/4W	R641	ERDS2TJ223T	22K 1/4W
R524	ERD2FCG390	39 1/4W	R573	ERDS2TJ103T	10K 1/4W	R642	ERDS2TJ683T	68K 1/4W
R525	ERDS1FVJ100T	10 1/2W Δ	R579	ERDS1FVJ470T	47 1/2W Δ	R651	ERDS2TJ472T	4.7K 1/4W
R526	ERDS2TJ151T	150 1/4W	R581	ERDS2TJ823T	82K 1/4W	R652	ERDS2TJ472T	4.7K 1/4W
R527	ERDS1FVJ182T	1.8K 1/2W Δ	R582	ERDS2TJ124T	120K 1/4W	R655	ERDS2TJ682T	6.8K 1/4W
R528	ERD2FCG390	39 1/4W	R583	ERDS2TJ563T	56K 1/4W	R656	ERDS2TJ682T	6.8K 1/4W
R529	ERDS2TJ151T	150 1/4W	R586	ERDS2TJ103T	10K 1/4W	R657	ERDS2TJ123T	12K 1/4W
R530	ERDS1FVJ152T	1.5K 1/2W Δ	R587	ERDS1FVJ121T	120 1/2W Δ	R658	ERDS2TJ123T	12K 1/4W
R531	ERDS2TJ102T	1K 1/4W	R588	ERDS1FVJ3R3T	3.3 1/2W Δ	R659	ERDS2TJ181T	180 1/4W
R532	ERDS2TJ153T	15K 1/4W	R589	ERDS1FVJ3R3T	3.3 1/2W Δ	R660	ERDS2TJ181T	180 1/4W
R533	ERDS2TJ183T	18K 1/4W	R590	ERDS1FVJ3R3T	3.3 1/2W Δ	R681	ERDS2TJ271T	270 1/4W
R534	ERDS2TJ472T	4.7K 1/4W	R591	ERDS1FVJ3R3T	3.3 1/2W Δ	R682	ERDS2TJ271T	270 1/4W
R535	ERDS1FVJ121T	120 1/2W Δ	R597	ERX12SJR27E	0.27 1/2W Δ	R801	ERDS2TJ102T	1K 1/4W
R536	ERDS1FVJ121T	120 1/2W Δ	R601	ERDS2TJ103T	10K 1/4W	R802	ERDS2TJ102T	1K 1/4W
R537	ERDS2TJ103T	10K 1/4W	R602	ERDS2TJ102T	1K 1/4W	R803	ERDS2TJ472T	4.7K 1/4W
R538	ERDS2TJ103T	10K 1/4W	R603	ERDS2TJ102T	1K 1/4W	R804	ERDS2TJ472T	4.7K 1/4W
R539	ERDS2TJ472T	4.7K 1/4W	R604	ERDS2TJ122T	1.2K 1/4W	R805	ERDS2TJ103T	10K 1/4W
R540	ERDS2TJ472T	4.7K 1/4W	R605	ERDS2TJ182T	1.8K 1/4W	R806	ERDS2TJ103T	10K 1/4W
R541	ERDS2TJ681T	680 1/4W	R606	ERDS2TJ222T	2.2K 1/4W	R807	ERDS2TJ153T	15K 1/4W
R542	ERDS2TJ152T	1.5K 1/4W	R607	ERDS2TJ272T	2.7K 1/4W	R808	ERDS2TJ153T	15K 1/4W
R543	ERDS2TJ472T	4.7K 1/4W	R608	ERDS2TJ472T	4.7K 1/4W	R809	ERDS2TJ823T	82K 1/4W
R545	ERX1SJR22E	0.22 1/2W Δ	R611	ERDS2TJ103T	10K 1/4W	R810	ERDS2TJ823T	82K 1/4W
R546	ERX1SJR22E	0.22 1/2W Δ	R612	ERDS2TJ102T	1K 1/4W	R815	ERDS2TJ182T	1.8K 1/4W
R547	ERX1SJR22E	0.22 1/2W Δ	R613	ERDS2TJ102T	1K 1/4W	R816	ERDS2TJ182T	1.8K 1/4W

Ref. No.	Part No.	Values & Remarks	Ref. No.	Part No.	Values & Remarks	Ref. No.	Part No.	Values & Remarks
C510	ECEA2AU100B	10 100V	C652	ECEA1EU330B	33 25V	C818	ECEA1HUR22B	0.22 50V
C511	ECKR1H223ZF5	0.022 50V	C653	ECBT1C682MR5	6800P 16V	C819	ECEA1AU470B	47 10V
C512	ECKR1H223ZF5	0.022 50V	C654	ECBT1C682MR5	6800P 16V	C820	ECEA1HU010B	1 50V
C513	ECEA1HU010B	1 50V	C655	ECBT1H471KB5	470P 50V	C821	ECEA1HU0R1B	0.1 50V
C514	ECEA1HU010B	1 50V	C656	ECBT1H471KB5	470P 50V	C822	ECEA1HU0R1B	0.1 50V
C515	ECBT1E223ZF5	0.022 25V	C657	ECFR1C223KR	0.022 16V	C823	ECEA1HKR68B	0.68 50V
C520	ECEA1CU101B	100 16V	C658	ECFR1C223KR	0.022 16V	C824	ECEA1HKR68B	0.68 50V
C521	ECEA1CU101B	100 16V	C659	ECBT1C152KR5	1500P 16V	C827	ECEA1HU010B	1 50V
C522	ECEA0JU101B	100 6.3V	C660	ECBT1C152KR5	1500P 16V	C829	ECBT1H102KB5	0.001 50V
C523	ECEA0JU101B	100 6.3V	C661	ECFR1C683KR	0.068 16V	C830	ECBT1H102KB5	0.001 50V
C524	ECEA1EU4R7B	4.7 25V	C662	ECFR1C683KR	0.068 16V	C901	ECBT1H102KB5	0.001 50V
C525	ECEA1EU4R7B	4.7 25V	C663	ECBT1C472KR5	4700P 16V	C902	ECS5R5H473	0.047 5.5V
C526	ECEA1HU010B	1 50V	C664	ECBT1C472KR5	4700P 16V	C903	ECEA0JU101B	100 6.3V
C528	ECEA1AU101B	100 10V	C665	ECEA1HUR22B	0.22 50V	C904	ECBT1H102KB5	0.001 50V
C529	ECKR1H103ZF5	0.01 50V	C666	ECEA1HUR22B	0.22 50V	C905	ECEA0JU101	100 6.3V
C530	ECEA1HU222E	2200 50V	C667	ECFR1C153KR	0.015 16V	C906	ECBT1H680J5	68P 50V
C531	ECKR1H103ZF5	0.01 50V	C668	ECFR1C153KR	0.015 16V	C907	ECBT1H680J5	68P 50V
C532	ECKR1H103ZF5	0.01 50V	C669	ECEA1HKR68B	0.68 50V	C908	ECBT1H101KB5	100P 50V
C533	ECKR1H103ZF5	0.01 50V	C670	ECEA1HKR68B	0.68 50V	C909	ECBT1H820KB5	82P 50V
C534	ECKR1H103ZF5	0.01 50V	C671	ECFR1C473KR	0.047 16V	C910	ECBT1H102KB5	0.001 50V
C535	ECEA1CU101B	100 16V	C672	ECFR1C473KR	0.047 16V	C911	ECBT1H102KB5	0.001 50V
C536	ECBT1E103ZF5	0.01 25V	C673	ECEA1EU4R7B	4.7 25V	C912	ECBT1H180JC5	18P 50V
C537	ECEA1CU101B	100 16V	C674	ECEA1EU4R7B	4.7 25V	C913	ECBT1H220JC5	22P 50V
C538	ECKR1H103ZF5	0.01 50V	C675	ECEA1CU100B	10 16V	C914	ECBT1H561KB5	560P 50V
C539	ECKR1H103ZF5	0.01 50V	C676	ECEA1CU100B	10 16V	C915	ECBT1H561KB5	560P 50V
C540	ECEA1HU2R2B	2.2 50V	C677	ECBT1H101KB5	100P 50V	C916	ECBT1H561KB5	560P 50V
C541	ECEA1HU332UE	3300 50V	C678	ECBT1H101KB5	100P 50V	C917	ECEA1HU010B	1 50V
C542	ECEA1HU332UE	3300 50V	C679	ECBT1H101KB5	100P 50V	C918	ECBT1C103MS5	0.01 16V
C543	ECQE1224KZ	0.22 100V	C680	ECBT1H101KB5	100P 50V	C919	ECEA1AU470B	47 10V
C544	ECBT1C103MS5	0.01 16V	C681	ECEA1CU100B	10 16V	C920	ECBT1C103MS5	0.01 16V
C551	ECBT0J223MS5	0.022 6.3V	C682	ECEA1CU100B	10 16V	C921	ECEA1AU220B	22 10V
C552	ECBT0J223MS5	0.022 6.3V	C801	ECEA1HU3R3B	3.3 50V	C922	ECEA1HU010B	1 50V
C553	ECQV1H104JZ3	0.1 50V	C802	ECEA1HU3R3B	3.3 50V	C923	ECBT1C103MS5	0.01 16V
C554	ECQV1H104JZ3	0.1 50V	C803	ECKR1H103ZF5	0.01 50V	C924	ECBT1H102KB5	0.001 50V
C555	ECQV1H224JZ3	0.22 50V	C804	ECEA1CU220B	22 16V	C925	ECBT1H330J5	33P 50V
C556	ECQV1H224JZ3	0.22 50V	C805	ECEA1CU220B	22 16V	C926	ECEA1AU471B	470 10V
C557	ECEA1HU3R3B	3.3 50V	C806	ECEA1CU221B	220 16V	C927	ECBT1C103MS5	0.01 16V
C558	ECEA1HU3R3B	3.3 50V	C807	ECEA1HUR33B	0.33 50V	C928	ECBT1H102KB5	0.001 50V
C559	ECBT1C103MS5	0.01 16V	C808	ECEA1HUR33B	0.33 50V	C929	ECEA1HU010B	1 50V
C560	ECBT1C103MS5	0.01 16V	C809	ECBT1H100JC5	10P 50V	C930	ECFR1C683KR	0.068 16V
C563	ECKR1H103ZF5	0.01 50V	C810	ECBT1H100JC5	10P 50V	C931	ECFR1C683KR	0.068 16V
C564	ECKR1H103ZF5	0.01 50V	C811	ECEA1HU3R3B	3.3 50V	C936	ECBT1H102KB5	0.001 50V
C582	ECEA0JN101SB	100 6.3V	C812	ECEA1HU3R3B	3.3 50V	C937	ECBT1H102KB5	0.001 50V
C601	ECBT1H561KB5	560P 50V	C813	ECKR1H103ZF5	0.01 50V	C938	ECBT1H102KB5	0.001 50V
C602	ECBT1H561KB5	560P 50V	C814	ECKR1H103ZF5	0.01 50V	C939	ECBT1H102KB5	0.001 50V
C603	ECBT1H561KB5	560P 50V	C815	ECEA1HKR68B	0.68 50V	C951	ECBT1C103MS5	0.01 16V
C604	ECBT1H561KB5	560P 50V	C816	ECEA1HKR68B	0.68 50V	C952	ECBT1C103MS5	0.01 16V
C651	ECEA1EU330B	33 25V	C817	ECEA1HUR22B	0.22 50V	C953	ECBT1C103MS5	0.01 16V

Ref. No.	Part No.	Values & Remarks	Ref. No.	Part No.	Values & Remarks	Ref. No.	Part No.	Values & Remarks
R817	ERDS2TJ683T	68K 1/4W	R923	ERDS2TJ103T	10K 1/4W	C10	ECEA1CU100B	10 16V
R818	ERDS2TJ683T	68K 1/4W	R925	ERDS2TJ225T	2.2M 1/4W	C10T(E/B/GN)	ECBT1H102KB5	0.001 50V
R819	ERDS2TJ682T	6.8K 1/4W	R926	ERDS2TJ474T	470K 1/4W	C11	ECBT1H330J5	33P 50V
R820	ERDS2TJ682T	6.8K 1/4W	R927	ERDS2TJ474T	470K 1/4W	C11T(E/B/GN)	ECBT1H6R8KC5	6.8P 50V
R821	ERDS2TJ105T	1M 1/4W	R928	ERDS2TJ103T	10K 1/4W	C12	ECKR1H223ZF5	0.022 50V
R823	ERDS2TJ474T	470K 1/4W	R929	ERDS2TJ474T	470K 1/4W	C12T(E/B/GN)	ECBT1H102KB5	0.001 50V
R824	ERDS2TJ102T	1K 1/4W	R930	ERDS2TJ474T	470K 1/4W	C13	ECKR1H223ZF5	0.022 50V
R825	ERDS2TJ472T	4.7K 1/4W	R931	ERDS2TJ103T	10K 1/4W	C13T(E/B/GN)	ECBT1H3R3KC5	3.3P 50V
R826	ERDS2TJ472T	4.7K 1/4W	R932	ERDS2TJ103T	10K 1/4W	C14	ECBT1H100JC5	10P 50V
R827	ERDS2TJ182T	1.8K 1/4W	R951	ERDS2TJ223T	22K 1/4W	C14T(E/B/GN)	ECBT1H180JC5	18P 50V
R828	ERDS2TJ182T	1.8K 1/4W	R952	ERDS2TJ823T	82K 1/4W	C15	ECBT1C103NS5	0.01 16V
R829	ERDS2TJ473T	47K 1/4W	R953	ERDS2TJ823T	82K 1/4W	C15T(E/B/GN)	ECBT1C103NS5	0.01 16V
R830	ERDS2TJ473T	47K 1/4W	R954	ERDS2TJ823T	82K 1/4W	C16	ECEA1CU100B	10 16V
R831	ERDS2TJ102T	1K 1/4W	R958	ERDS2TJ104T	100K 1/4W	C16T(E/B/GN)	ECBT1C103NS5	0.01 16V
R832	ERDS2TJ102T	1K 1/4W	R960	ERDS2TJ103T	10K 1/4W	C17	ECEA1HU010B	1 50V
R833	ERDS2TJ332T	3.3K 1/4W	R961	ERDS2TJ103T	10K 1/4W	C17T(E/B/GN)	ECBT1H102KB5	0.001 50V
R835	ERDS2TJ222T	2.2K 1/4W	R962	ERDS2TJ103T	10K 1/4W	C18	ECBT1C103NS5	0.01 16V
R836	ERDS2TJ222T	2.2K 1/4W	R963	ERDS2TJ103T	10K 1/4W	C18T(E/B/GN)	ECBT1H102KB5	0.001 50V
R837	ERDS2TJ105T	1M 1/4W	R967	ERDS2TJ103T	10K 1/4W	C19	ECEA1CU100B	10 16V
R838	ERDS2TJ334T	330K 1/4W	R968	ERDS2TJ102T	1K 1/4W	C19T(E/B/GN)	ECBT1H102KB5	0.001 50V
R840	ERDS2TJ472T	4.7K 1/4W	R969	ERDS2TJ102T	1K 1/4W	C20	ECBT1H101KB5	100P 50V
R841	ERDS2TJ152T	1.5K 1/4W	R970	ERDS2TJ102T	1K 1/4W	C21	ECFRIC333MR	0.033 16V
R842	ERDS2TJ473T	47K 1/4W	R971	ERDS2TJ102T	1K 1/4W	C22	ECBT1C103NS5	0.01 16V
R843	ERDS2TJ223T	22K 1/4W	R972	ERDS2TJ102T	1K 1/4W	C23	ECBT0J223NS5	0.022 6.3V
R844	ERDS2TJ223T	22K 1/4W	R973	ERDS2TJ470T	47 1/4W	C24	ECEA1CU100B	10 16V
R845	ERDS2TJ681T	680 1/4W	R974	ERDS2TJ470T	47 1/4W	C25	ECBT1H471KB5	470P 50V
R901	ERDS2TJ331T	330 1/4W				C26	ECFRIC473KR	0.047 16V
R902	ERDS2TJ102T	1K 1/4W				C27	ECBT1H100JC5	10P 50V
R903	ERDS2TJ334T	330K 1/4W				C28	ECBT1C103NS5	0.01 16V
R904	ERDS2TJ102T	1K 1/4W				C29	ECBT1C103NS5	0.01 16V
R905	ERDS2TJ473T	47K 1/4W	C1	ECBT1C103NS5	0.01 16V	C30	ECEA25M4R7RB	4.7 25V
R906	ERDS2TJ561T	560 1/4W	C1T(E/B/GN)	ECBT1H6R8KC5	6.8P 50V	C31	ECBT1C103NS5	0.01 16V
R907	ERDS2TJ104T	100K 1/4W	C2	ECBT1C103NS5	0.01 16V	C34	ECEA1CU330B	33 16V
R908	ERDS2TJ104T	100K 1/4W	C2T(E/B/GN)	ECBT1H102KB5	0.001 50V	C35	ECBT1H150J5	15P 50V
R909	ERDS2TJ472T	4.7K 1/4W	C3	ECBT1H470J5	47P 50V	C36	ECBT1H150J5	15P 50V
R910	ERDS2TJ472T	4.7K 1/4W	C3T(E/B/GN)	ECBT1H102KB5	0.001 50V	C37	ECBT1H102KB5	0.001 50V
R911	ERDS2TJ472T	4.7K 1/4W	C4	ECBT1H102KB5	0.001 50V	C38	ECBT1H102KB5	0.001 50V
R912	ERDS2TJ472T	4.7K 1/4W	C4T(E/B/GN)	ECBT1H3R3KC5	3.3P 50V	C39	ECEA0JU221B	220 6.3V
R913	ERDS2TJ472T	4.7K 1/4W	C5	ECBT1H150J5	15P 50V	C40	ECBT1H181KB5	180P 50V
R914	ERDS2TJ472T	4.7K 1/4W	C5T(E/B/GN)	ECBT1H2R2KC5	2.2P 50V	C41	ECBT1H102KB5	0.001 50V
R915	ERDS2TJ224T	220K 1/4W	C6	ECBT1C103NS5	0.01 16V	C42	ECBT1H102KB5	0.001 50V
R916	ERDS2TJ104T	100K 1/4W	C6T(E/B/GN)	ECBT1H3R3KC5	3.3P 50V	C43	ECEA1CU330B	33 16V
R917	ERDS2TJ104T	100K 1/4W	C7	ECEA1CU100B	10 16V	C50	ECEA1CU101B	100 16V
R918	ERDS2TJ103T	10K 1/4W	C7T(E/B/GN)	ECBT1H102KB5	0.001 50V	C52	ECBT1H102KB5	0.001 50V
R919	ERDS2TJ103T	10K 1/4W	C8	ECBT1C103NS5	0.01 16V	C53	ECBT1H102KB5	0.001 50V
R920	ERDS2TJ472T	4.7K 1/4W	C8T(E/B/GN)	ECBT1H120JC5	12P 50V	C54	ECEA1HU3R3B	3.3 50V
R921	ERDS2TJ103T	10K 1/4W	C9	ECEA0JU101B	100 6.3V	C55	ECEA1HU3R3B	3.3 50V
R922	ERDS2TJ682T	6.8K 1/4W	C9T(E/B/GN)	ECBT1H181KB5	180P 50V	C56	ECFRIC392JR	3900P 16V

Ref. No.	Part No.	Values & Remarks	Ref. No.	Part No.	Values & Remarks	Ref. No.	Part No.	Values & Remarks
C57	ECFR1C392JR	3900P 16V	C140	ECEA1CU100B	10 16V	C202	ECBT1H104ZF5	0.1 50V
C58	ECFR1C822KR	8200P 16V	C141	ECEA1HU0R1B	0.1 50V	C302	ECFR1E104ZF5	0.1 25V
C59	ECFR1C822KR	8200P 16V	C142	ECFR1C223MR	0.022 16V	C303	ECFR1E104ZF5	0.1 25V
C61	ECEA1HUR47B	0.47 50V	C143	ECEA1HU010B	1 50V	C304	ECEA1EU4R7B	4.7 25V
C62	ECEA1HU010B	1 50V	C144	ECEA1HU010B	1 50V	C305	ECEA1HU3R3B	3.3 50V
C63	ECEA1HU3R3B	3.3 50V	C145	ECEA1CU100B	10 16V	C306	ECEA1HU3R3B	3.3 50V
C64	ECQP2A471JZT	470P 100V	C146	ECEA1CU100B	10 16V	C307	ECEA1HU3R3B	3.3 50V
C65	ECEA1VU4R7B	4.7 35V	C150	ECEA1AU470B	47 10V	C308	ECEA1HU3R3B	3.3 50V
C66	ECQV1H473JZ3	0.047 50V	C151	ECEA1HU010B	1 50V	C309	ECEA1CU100B	10 16V
C71	ECBT1H104ZF5	0.1 50V	C152	ECEA1HU010B	1 50V	C310	ECEA0JU101B	100 6.3V
C101	ECBT1H102KB5	0.001 50V	C153	ECBT1H331KB5	330P 50V	C323	ECBT1H101KB5	100P 50V
C102	ECBT1H102KB5	0.001 50V	C154	ECBT1H331KB5	330P 50V	C324	ECBT1H101KB5	100P 50V
C103	ECBT1H681KB5	680P 50V	C155	ECEA1CU100B	10 16V	C327	ECBT1H102KB5	0.001 50V
C104	ECFR1C223MR	0.022 16V	C156	ECEA1CU100B	10 16V	C328	ECBT1H102KB5	0.001 50V
C105	ECBT1H471KB5	470P 50V	C157	ECBT1H681KB5	680P 50V	C329	ECEA1HU010B	1 50V
C106	ECBT1H471KB5	470P 50V	C158	ECBT1H681KB5	680P 50V	C330	ECKR1H103ZF5	0.01 50V
C107	ECBT1H681KB5	680P 50V	C159	ECBT1C682KR5	6800P 16V	C331	ECBT1H151KB5	150P 50V
C108	ECEA1AU330B	33 10V	C160	ECBT1C682KR5	6800P 16V	C332	ECBT1H151KB5	150P 50V
C109	ECEA1AU101B	100 10V	C161	ECEA1CU101B	100 16V	C333	ECBT1H151KB5	150P 50V
C111	ECBT1H471KB5	470P 50V	C162	ECA0JM471B	470P 6.3V	C334	ECKR1H472KB5	4700P 50V
C112	ECBT1H471KB5	470P 50V	C163	ECEA1HU010B	1 50V	C335	ECKR1H472KB5	4700P 50V
C113	ECEA0JU221B	220 6.3V	C164	ECEA1HK010B	1 50V	C336	ECBT1H330J5	33P 50V
C114	ECEA0JU221B	220 6.3V	C165	ECEA1CK100B	10 16V	C337	ECBT1H330J5	33P 50V
C115	ECFR1C333JR	0.033 16V	C166	ECEA1CU100B	10 16V	C338	ECBT1H102KB5	0.001 50V
C116	ECFR1C333JR	0.033 16V	C167	ECEA50ZR68	0.68 50V	C341	ECEA1HU010B	1 50V
C117	ECEA1HK010B	1 50V	C168	ECEA50ZR68	0.68 50V	C342	ECEA1HU010B	1 50V
C118	ECEA1HU010B	1 50V	C169	ECEA1EU4R7B	4.7 25V	C344	ECBT1H102KB5	0.001 50V
C119	ECEA1EU4R7B	4.7 25V	C170	ECEA1EU4R7B	4.7 25V	C345	ECKR1H101KB5	100P 50V
C120	ECEA1EU4R7B	4.7 25V	C171	ECEA0JKS470B	47 6.3V	C346	ECBT1H102KB5	0.001 50V
C121	ECEA1HU010B	1 50V	C173	ECBT1C103MS5	0.01 16V	C347	ECBT1H102KB5	0.001 50V
C122	ECEA1HU010B	1 50V	C174	ECEA1HU010B	1 50V	C348	ECFR1E104ZF5	0.1 25V
C123	ECBT1H102KB5	0.001 50V	C175	ECEA1CU101B	100 16V	C349	ECFR1E104ZF5	0.1 25V
C124	ECBT1H102KB5	0.001 50V	C176	ECQV1H473JZ3	0.047 50V	C350	ECBT1H151KB5	150P 50V
C125	ECFR1C473MR	0.047 16V	C177	ECBT1H102KB5	0.001 50V	C353	ECBT1H101KB5	100P 50V
C126	ECFR1C473MR	0.047 16V	C178	ECBT1H102KB5	0.001 50V	C354	ECBT1H101KB5	100P 50V
C127	ECBT1C332KR5	3300P 16V	C179	ECFR1C103KR	0.01 16V	C401	ECBT1H331KB5	330P 50V
C128	ECBT1C332KR5	3300P 16V	C180	ECFR1C103MR	0.01 16V	C402	ECBT1H331KB5	330P 50V
C129	ECBT1H151KB5	150P 50V	C181	ECFR1C103MR	0.01 16V	C451	ECKR1H103ZF5	0.01 50V
C130	ECBT1H151KB5	150P 50V	C182	ECEA1AU470B	47 10V	C452	ECKR1H103ZF5	0.01 50V
C131	ECBT1H221KB5	220P 50V	C183	ECQV1H474JZ3	0.47 50V	C453	ECKR1H103ZF5	0.01 50V
C132	ECBT1H221KB5	220P 50V	C184	ECQP1152JZ	1500P 100V	C454	ECEA1AU101B	100 10V
C133	ECEA1EU4R7B	4.7 25V	C185	ECQP2A472JZT	4700P 100V	C503	ECBT1H102KB5	0.001 50V
C134	ECEA1EU4R7B	4.7 25V	C186	ECEA1AU470B	47 10V	C504	ECBT1H102KB5	0.001 50V
C135	ECBT1H102KB5	0.001 50V	C187	ECBT1H101KB5	100P 50V	C505	ECBT1H102KB5	0.001 50V
C136	ECBT1H102KB5	0.001 50V	C188	ECBT1H101KB5	100P 50V	C506	ECBT1H102KB5	0.001 50V
C137	ECFR1C183KR	0.018 16V	C189	ECQP1272JZ	2700P 100V	C507	ECBT1H150JC5	15P 50V
C138	ECFR1C183KR	0.018 16V	C190	ECBT1C103MS5	0.01 16V	C508	ECBT1H150JC5	15P 50V
C139	ECEA1HU2R2B	2.2 50V	C201	ECEA1CK101B	100 16V	C509	ECEA1HU220B	22 50V

Ref. No.	Part No.	Values & Remarks	Ref. No.	Part No.	Values & Remarks	Ref. No.	Part No.	Values & Remarks
C954	ECBT1H102KB5	0.001 50V				C756,757	ECUV1H050DCN	5P 50V
C955	ECEA1CU100B	10 16V		CAPACITORS		C758	ECUV1C224KBM	0.22 16V
C956	ECBT1H102KB5	0.001 50V				C763	ECUV1E103MBN	0.01 25V
			C701	ECEA0JKA220	22 6.3V			
	<SERVO P.C.B.>		C702	ECEA0JKS470	47 6.3V			
			C703	ECEA0JKS101I	100 6.3V			
	RESISTORS		C709	ECUV1C224KBM	0.22 16V			
			C710	ECUV1C104MBM	0.1 16V			
R701	ERJ6GEYJ100	10 1/10W	C711	ECUV1E103MBN	0.01 25V			
R702	ERJ6GEYJ471V	470 1/10W	C713	ECEA1CSN4R7I	4.7 16V			
R703	ERJ6GEYJ102V	1K 1/10W	C714	ECEA1HKS010	1 50V			
R704	ERJ6GEYJ103V	10K 1/10W	C715	ECUV1H472KBN	4700P 50V			
R706	ERJ6GEYJ473V	47K 1/10W	C716	ECUV1C473KBN	0.047 16V			
R707	ERJ6GEYJ222V	2.2K 1/10W	C717	ECUV1H681KBN	680P 50V			
R708	ERJ6GEYJ683V	68K 1/10W	C718	ECEA1AKS101I	100 10V			
R709	ERJ6GEYJ122V	1.2K 1/10W	C719	ECUV1E103MBN	0.01 25V			
R710	ERJ6GEYJ182V	1.8K 1/10W	C720	ECUV1E153MBN	0.015 25V			
R711	ERJ6GEYJ473V	47K 1/10W	C721	ECUV1E103MBN	0.01 25V			
R712	ERJ6GEYJ471V	470 1/10W	C722	ECEA0JKS470	47 6.3V			
R714	ERJ6GEYJ473V	47K 1/10W	C723	ECUV1C104MBM	0.1 16V			
R715	ERJ6GEYJ223V	22K 1/10W	C724	ECUV1E333MBN	0.033 25V			
R716	ERJ6GEYJ104V	100K 1/10W	C725	ECUV1E103MBN	0.01 25V			
R717	ERJ6GEYJ682V	6.8K 1/10W	C726	ECUV1H471KBN	470P 50V			
R718	ERJ6GEYJ223V	22K 1/10W	C727	ECEA0JKS470	47 6.3V			
R719	ERJ6GEYJ123V	12K 1/10W	C728,729	ECUV1C104MBM	0.1 16V			
R720	ERJ6GEYJ 273V	27K 1/10W	C730	ECUV1C224KBM	0.22 16V			
R721	ERJ6GEYJ823	82K 1/10W	C731	ECEA0JKS331I	330 6.3V			
R722	ERJ6GEYJ102V	1K 1/10W	C732	ECUV1H102MBN	1000P 50V			
R723,724	ERJ6GEYJ104V	100K 1/10W	C733	ECEA0JKS101I	100 6.3V			
R725	ERJ6GEYJ471V	470 1/10W	C734	ECUV1E223MBN	0.022 25V			
R726	ERJ6GEYJ102V	1K 1/10W	C735	ECUV1C224KBM	0.22 16V			
R729,730	ERJ6GEYJ102V	1K 1/10W	C737	ECUV1C224KBM	0.22 16V			
R731	ERJ8GEYJ470V	47 1/8W	C738	ECEA0JKS101I	100 6.3V			
R732	ERJ6GEYJ562V	5.6K 1/10W	C739	ECUV1E103MBN	0.01 25V			
R733	ERJ6GEYJ332V	3.3K 1/10W	C740	ECUV1H472MBN	4700P 50V			
R734	ERJ6GEYJ562V	5.6K 1/10W	C741	ECUV1C224KBM	0.22 16V			
R735	ERJ6GEYJ222V	2.2K 1/10W	C742	ECUV1C104MBM	0.1 16V			
R736	ERJ6GEYJ682V	6.8K 1/10W	C743	ECEA0JKS331I	330 6.3V			
R737-739	ERJ6GEYJ562V	5.6K 1/10W	C744,745	ECUV1H102KBN	1000P 50V			
R741-743	ERJ6GEYJ102V	1K 1/10W	C746	ECEA0JKS101I	100 6.3V			
R744	ERJ6GEYJ393V	39K 1/10W	C747	ECUV1C104MBM	0.1 16V			
R745,746	ERJ6GEYJ102V	1K 1/10W	C748	ECEA1HKS010	1 50V			
R747	ERJ6GEYJ473V	47K 1/10W	C749	ECUV1E103MBN	0.01 25V			
R748	ERJ8GEYJ180V	18 1/8W	C750	ECUV1H050DCN	5P 50V			
			C751	ECUV1C224KBM	0.22 16V			
			C752	ECUV1C104MBM	0.1 16V			
			C753,754	ECEA1HKS010	1 50V			
			C755	ECUV1C104MBM	0.1 16V			

MECHANISM PARTS LOCATION

Notes : [M] Indicates in Remarks columns parts that are supplied by MESA.

Ref. No	Part No.	Part Name & Description	Remarks	Ref. No	Part No.	Part Name & Description	Remarks
		MECHANISM PARTS LIST		136	RUW145ZA	SPRING	
				137	1UB0090ZA	ROD	
		DECK 1		137-1	RUB512ZB	FF ROD	
101	RXQ0051-2	HEAD BLOCK (PLAYBACK)		138	RDG5773ZA	GEAR	
102	RUA793ZF	HEAD PANEL		139	RUQ112ZA	SPRING	
103	RUB501ZB	ROD		140	RUS609ZC	TAPE PRESSURE SPRING	
103-1	RUW143ZA	SPRING		141	RUB514ZC	LEVER	
104	1UB0089ZA	ARM		142	RUW147ZA	SPRING	
104-1	RUW148ZA	SPRING		143	RUB515ZA	LEVER	
105	1DM0018ZA	REEL TABLE (R)		144	RUB509ZA	LEVER	
106	1DM0017ZA	REEL TABLE (F)		145	RDV108ZA	CAPSTAN BELT	
107	RML0069-1	LEVER		148	RUW144ZA	SPRING	
108	RDG57727ZC	GEAR		149	RHG3032ZA	RUBBER CUSHION	
109	RUB508ZA	BRAKE ROD		150	RNL180ZB	DAMPER ARM B	
110	RUB506ZA	LEVER		151	REX0450	LEAD WIRE BLOCK (4P)	[M]
111	1UB0088ZA	ARM (R)		161	XTW2+6L	SCREW	
111-1	RUW141ZA	SPRING		163	XTN26+7J	SCREW	
112	1UB0087ZA	ARM (F)		164	RHE5203ZA	SCREW	
112-1	RUW140ZA	SPRING		165	XTW2+8S	SCREW	
114	RNL1ZD	DAMPER ARM A		166	XYCS+JF16	SCREW	
115	RUB503ZD	MAIN LEVER		167	RHD26002	SCREW	
116	RUA792XE	CHASSIS		168	RJS10T7ZA	CONNECTOR (10P) , J971	
117	RUW142ZA	SPRING					
118	RUD105ZA	SPRING					
120	RUW139ZA	SPRING					
121	RFM133ZA	DC MOTOR					
122	1UE0015ZA	PLUNGER					
123	RUB428ZE	MOVING IRON CORE					
124	RUL1030ZE	FW BRACKET					
125	RMD5014ZC	FW SUPPORT BASE					
126	RDG5927ZG	GEAR					
127	1DW0037ZA	FLYWHEEL (F) ASSY					
127-1	RNW139ZA	WASHER					
128	1DW0038ZA	FLYWHEEL (R) ASSY					
128-1	RNW138ZB	WASHER					
129	1DG0006ZA	REEL TABLE GEAR					
130	RUB513ZD	ARM					
131	1UB0091ZA	LEVER					
131-1	RUW146ZA	SPRING					
132	1DR0011ZA	MAIN PULLEY					
133	RDV90ZB	BELT					
134	RDG5769ZA	REEL TABLE GEAR					
135	RUQ111ZB	SPRING					

MECHANISM PARTS LOCATION • Deck 1

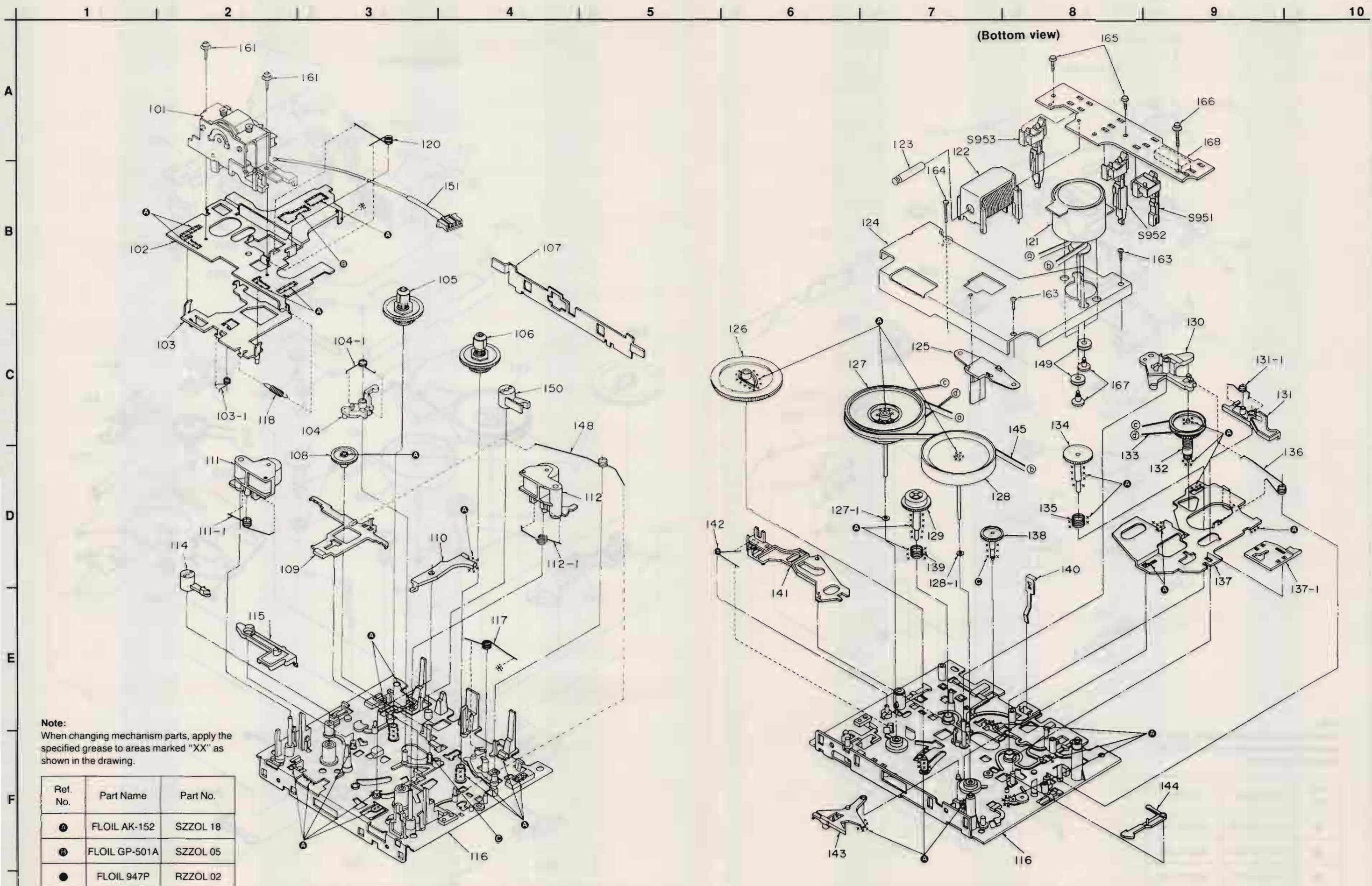

MECHANISM PARTS LOCATION • Deck 2

1 2 3 4 5 6 7 8 9 10

A

B

C

D

E

F

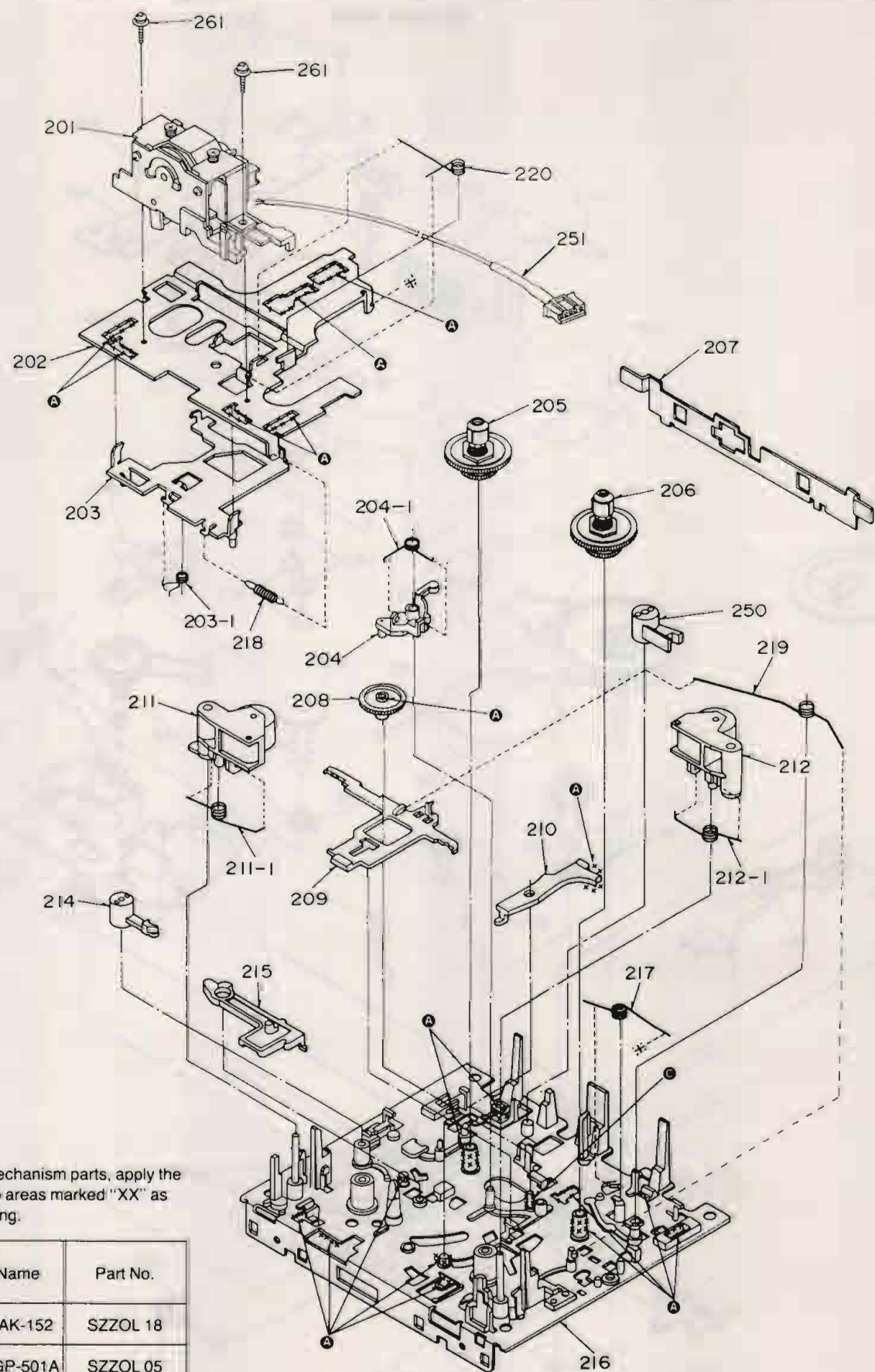

Note:
When changing mechanism parts, apply the specified grease to areas marked "XX" as shown in the drawing.

Ref. No.	Part Name	Part No.
●	FLOIL AK-152	SZZOL 18
●	FLOIL GP-501A	SZZOL 05
●	FLOIL 947P	RZZOL 02

(Bottom view)

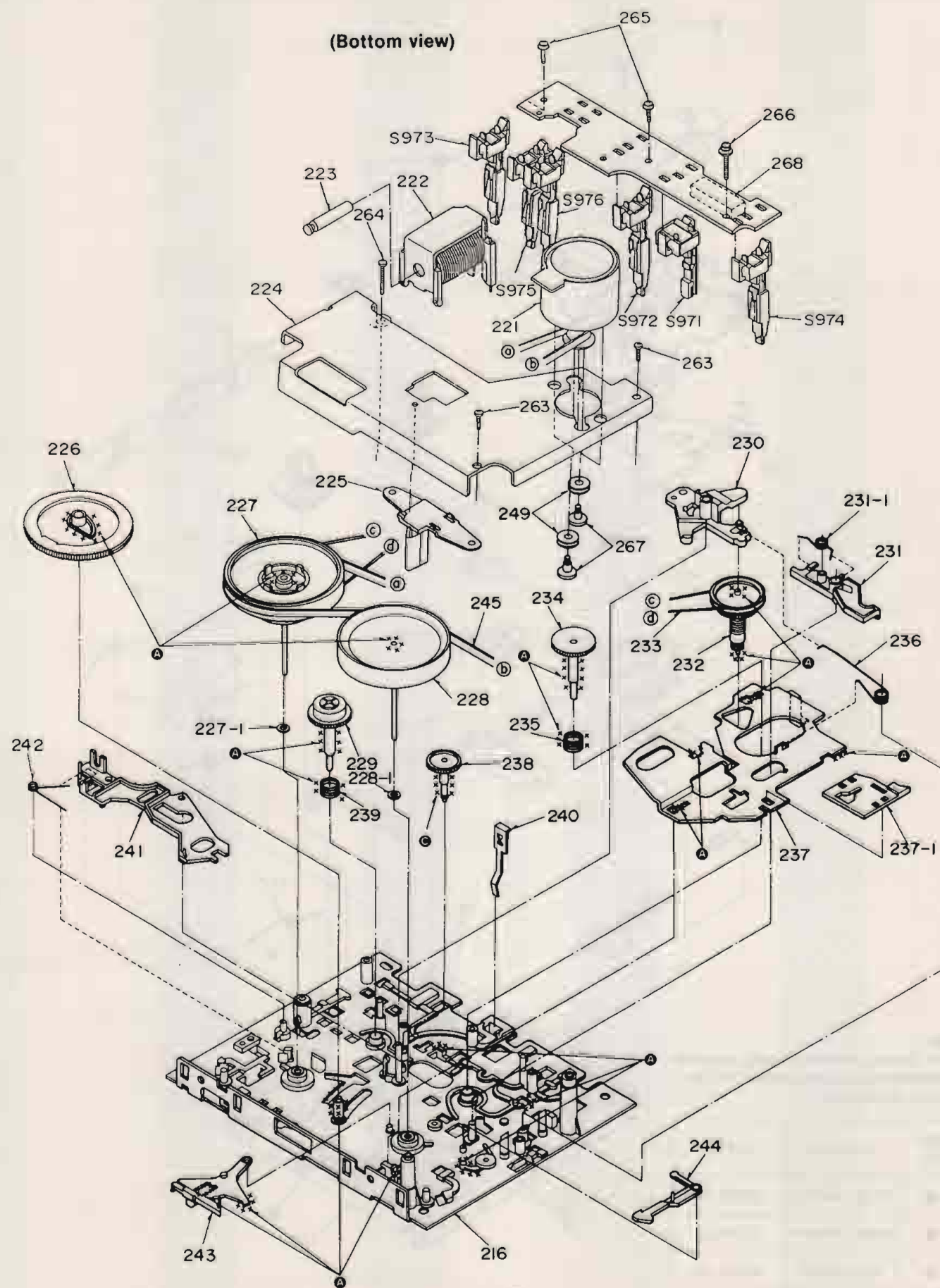

Ref. No	Part No.	Part Name & Description	Remarks
		MECHANISM PARTS LIST	
		DECK 2	
201	RXQ0007-2	HEAD BLOCK (REC. / PB.)	
202	RUA793ZF	HEAD PANEL	
203	RUB501ZB	ROD	
203-1	RUW143ZA	SPRING	
204	1UB0089ZA	ARM	
204-1	RUW148ZA	SPRING	
205	1DM0018ZA	REEL TABLE (R)	
206	1DM0017ZA	REEL TABLE (F)	
207	RML0069-1	LEVER	
208	RDG57727ZC	GEAR	
209	RUB508ZA	BRAKE ROD	
210	RUB506ZA	LEVER	
211	1UB0088ZA	ARM (R)	
211-1	RUW141ZA	SPRING	
212	1UB0087ZA	ARM (F)	
212-1	RUW140ZA	SPRING	
214	RNL1ZD	DAMPER ARM A	
215	RUB503ZD	MAIN LEVER	
216	RUA792XE	CHASSIS	
217	RUW142ZA	SPRING	
218	RUD105ZA	SPRING	
219	RUW144ZA	SPRING	
220	RUW139ZA	SPRING	
221	RFM133ZA	DC MOTOR	
222	1UE0015ZA	PLUNGER	
223	RUB428ZE	MOVING IRON CORE	
224	RUL1030ZE	FW BRACKET	
225	RMD5014ZC	FW SUPPORT BASE	
226	RDG5927ZG	GEAR	
227	1DW0037ZA	FLYWHEEL (F) ASSY	
227-1	RNW139ZA	WASHER	
228	1DW0038ZA	FLYWHEEL (R) ASSY	
228-1	RNW138ZB	WASHER	
229	1DG0006ZA	REEL TABLE GEAR	
230	RUB513ZD	ARM	
231	1UB0091ZA	LEVER	
231-1	RUW146ZA	SPRING	
232	1DR0011ZA	MAIN PULLEY	
233	RDV90ZB	BELT	
234	RDG5769ZA	REEL TABLE GEAR	
235	RUQ111ZB	SPRING	
236	RUW145ZA	SPRING	
237	1UB0090ZA	ROD	

Ref. No	Part No.	Part Name & Description	Remarks
237-1	RUB512ZB	FF ROD	
238	RDG5773ZA	GEAR	
239	RUQ112ZA	SPRING	
240	RUS609ZC	TAPE PRESSURE SPRING	
241	RUB514ZC	LEVER	
242	RUW147ZA	SPRING	
243	RUB515ZA	LEVER	
244	RUB509ZA	LEVER	
245	RDV108ZA	CAPSTAN BELT	
249	RHG3032ZA	RUBBER CUSHION	
250	RNL180ZB	DAMPER ARM B	
251	REX0305	LEAD WIRE BLOCK (5P)	[M]
261	XTW2+6L	SCREW	
263	XTN26+7J	SCREW	
264	RHE5203ZA	SCREW	
265	XTW2+8S	SCREW	
266	XYCS+JF16	SCREW	
267	RHD26002	SCREW	
268	RJS10T7ZA	CONNECTOR (10P) , J971	

TRAVERSE DECK LOCATION

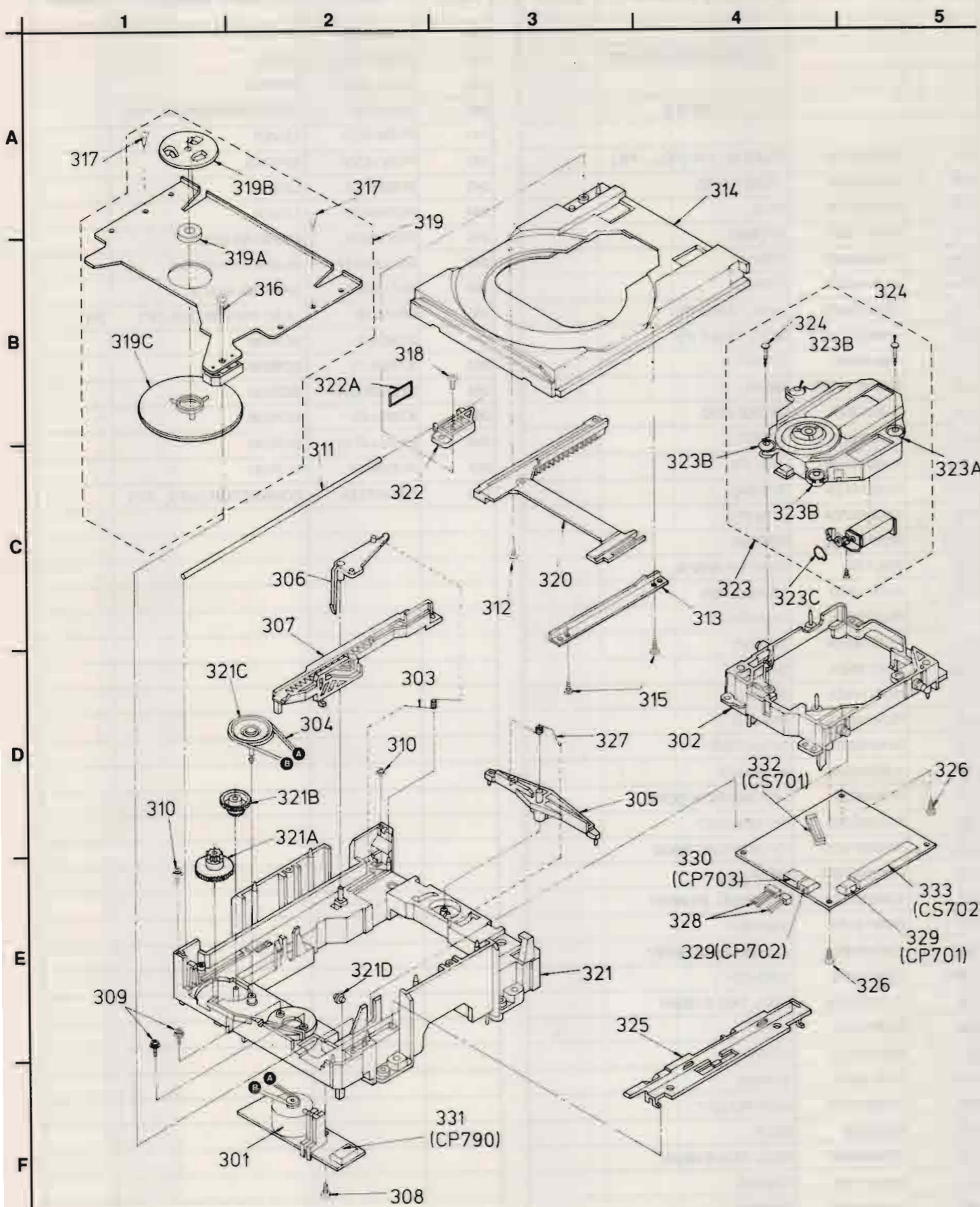

REPLACEMENT PARTS LIST

Notes : * Important safety notice:
 Components identified by Δ mark have special characteristics important for safety.
 Furthermore, special parts which have purposes of fire-retardant (resistors), high-quality sound (capacitors), low-noise (resistors), etc. are used.
 When replacing any of components, be sure to use only manufacturer's specified parts shown in the parts list.
 * The parenthesized indications in the Remarks columns specify the areas. (refer to the cover page for area.)
 Parts without these indications can be used for all areas.
 [M] Indicates in Remarks columns parts that are supplied by MESA.

Ref. No	Part No.	Part Name & Description	Remarks	Ref. No	Part No.	Part Name & Description	Remarks
TRAVERSE DECK				327	RME0087	SPRING	
301	REM0019	MOTOR ASS'Y		328	REE0217-1	CABLE ASS'Y	
302	RMK0105	CHASSIS		329	RJP2G17ZA	CONNECTOR (CP701, CP702)	
303	RME0063	SPRING		330	RJP4G17ZA	CONNECTOR (CP703)	
304	RMG0158	BELT		331	RJP6G17ZA	CONNECTOR (CP790)	
305	RML0177	LEVER		332	RJU035T016-1	CONNECTOR (CS701)	
306	RML0178	LEVER		333	RJS1A6723-1Q	CONNECTOR (CS702)	
307	RMM0058	SLIDE PLATE		ACCESSORIES			
308	XTN26+6G	SCREW		A1	RAK-SC307WM	REMOTE CONTROL	[M]
309	XYN2+F6FZ	SCREW		A1-1	RKK0008-KE	BATTERY COVER	[M]
310	RHD20012	SCREW		A2	RJA0019-U	AC CORD	Δ (E/EG)
311	RMU0046	SHAFT		A2	SJA193-1	AC CORD	Δ (EB)
312	RHD20009-1	SCREW		A2	SJA173	AC CORD	Δ (GN)
313	RMA0328	GUIDE		A3	SSA270M	FM ANT	[M](E/EB/EG)
314	RMK0103	TRAY		A3	SSA272	FM ANT.	(GN)
315	XTN2+8G	SCREW		A4	RQA0013	WARANTY CARD	(E/EB/EG)
316	XTB3+25GFZ	SCREW		A4	RQX7433ZA	WARANTY CARD	(GN)
317	XTN26+6G	SCREW		A5	RQT1535-G	INST. MNL. (ENG/ESP/FRN)	[M] (E)
318	XTN3+8JFZ	SCREW		A5	RQT1536-E	INST. MNL. (DEU/NED/SVN)	[M] (E)
319	RXQ0122	DISC CLAMPER ASS'Y		A5	RQT1537-B	INSTRUCTION MANUAL	[M](EB/GN)
319A	RHM245ZA	MAGNET		A5	RQT1534-D	INSTRUCTION MANUAL	[M] (EG)
319B	RMR0334	MAGNET HOLDER		A6	RQCB0169	SERVICE CENTRE LIST	[M]
319C	RXQ0123	DISC PAD		A7	SLA9Z5T	LOOP ANT	[M]
320	RFKNLDN7N-K	DRIVE GEAR (2) ASS'Y		A8	SMA233-1	ANT HOLDER	
321	RFKJXDT77-H	MECHANICAL CHASSIS ASS'Y		A9	SJP9009	DIN ADAPTOR	(EB)
321A	RDG0142	GEAR		A10	XTB3+10J	SCREW	
321B	RDG0143	GEAR		PACKING MATERIALS			
321C	RDP0041	PULLEY		P1	RPF0084	BAG (SET)	[M]
321D	SDRD14	ROLLER		P2	RPG1171	GIFT BOX	[M](E/EB/EG)
322	RFKNXDT77C-H	SHAFT HOLDER		P2	RPG1327	GIFT BOX	[M] (GN)
322A	RMG0159	RUBBER		P3	SPSD152	ACCESSORY CASE	
323	SODD110Z	TRAVERSE UNIT		P4	RPN0605	POLY FOAM	[M](E/EB/EG)
323A	SHGD112	RUBBER A		P4	RPN0598	POLYFOAM	[M] (GN)
323B	SHGD113-1	RUBBER B		P5	SPB1061	VINYL BAG	[M]
323C	RDV0014	BELT					
324	RMS0123-1	PIN					
325	RMM0059	SLIDE PLATE					
326	XTV26+6G	SCREW					

■ PACKING (SC-CH11GN)

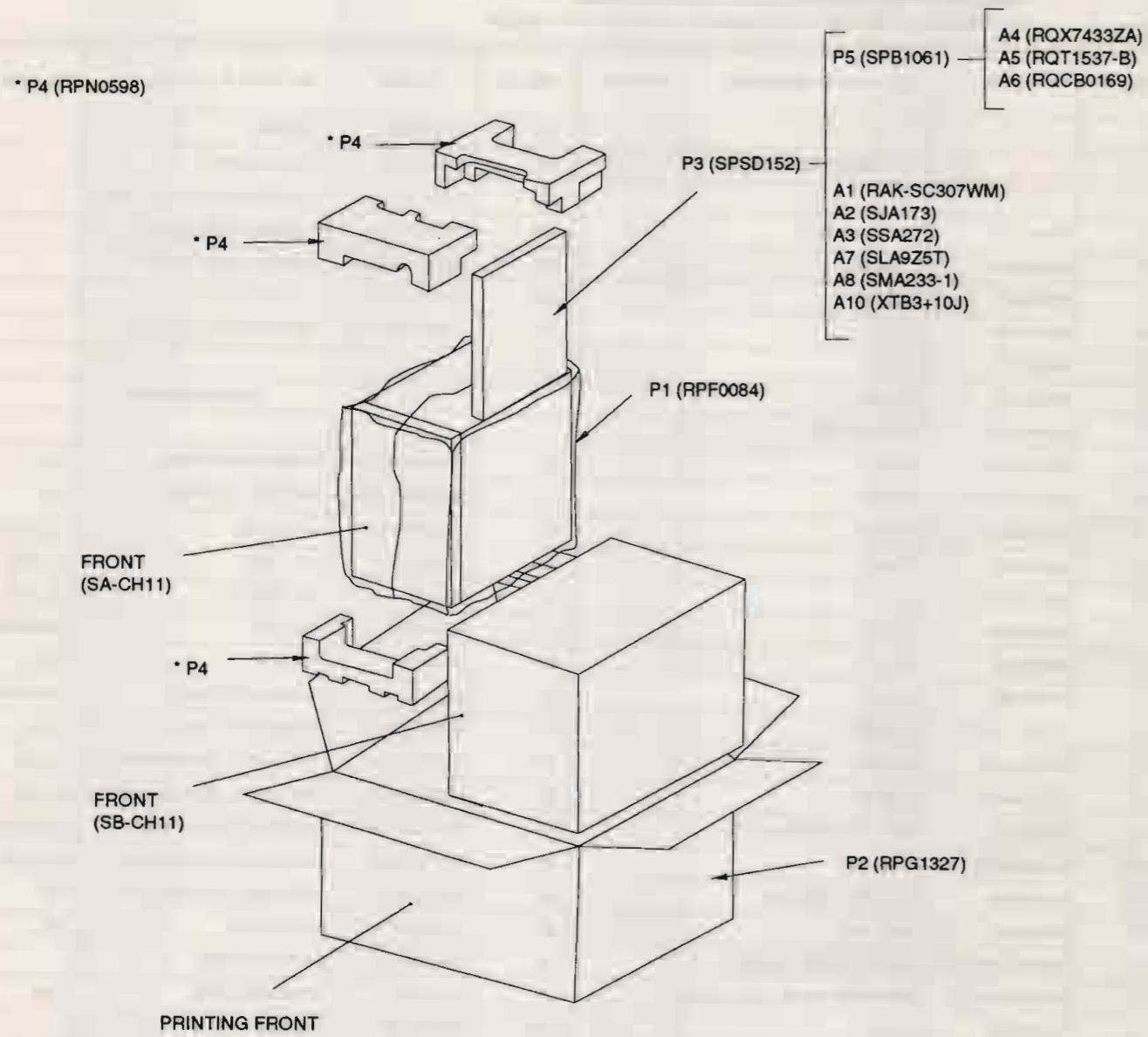

• SA-CH11 (E,EB,EG)

